

Trelleborg 560 Rieber IPS

Integrated seal
for plastic
pressure pipes

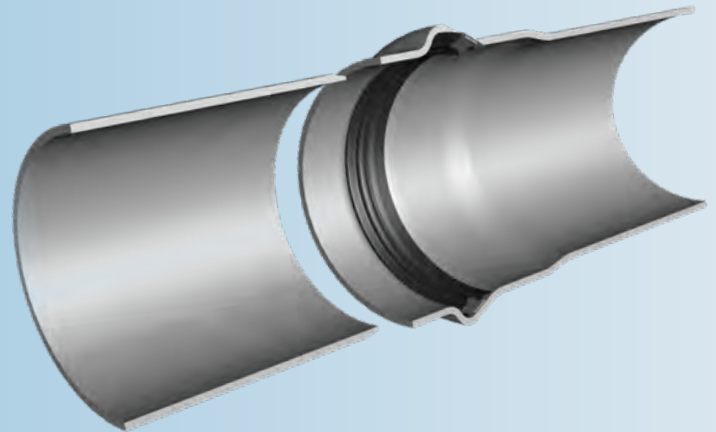

KEY FEATURES & BENEFITS

- **Greater joint reliability due to joint tolerance reduction**
- **Cannot be displaced or lost during stocking, transportation and installation**
- **Improved productivity and lower scrap rates**

SEAL DESIGN & FUNCTION

The Trelleborg 560 Rieber IPS is integrated into the pipe during the manufacturing process. It uses the mandrel together with the seal as a tool to form the pipe socket. This ensures that the seal always remains in the correct position in the joint.

The seal is equally effective under both positive and negative pipe pressure (vacuum). Under positive pressure, the higher the pressure the greater the sealing force. Under vacuum, the seal maintains a positive sealing force against spigot and socket, preventing sand or soil to enter the joint.

Trelleborg 560 Rieber IPS is a composite seal consisting of:

1. A flexible rubber element to seal effectively against spigot and socket
2. A treated metal insert which holds the seal firmly in place

JOINT ASSEMBLY

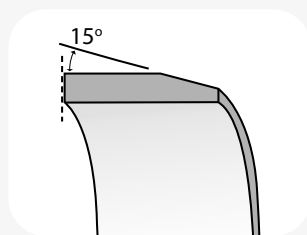

Inspect the spigot, socket and seal for damage and remove any dirt or dust prior to assembly.

Chamfer the spigot end and remove all burrs.

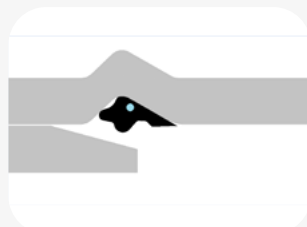

Apply lubricant to the spigot end and immediately bring it into contact with the socket.

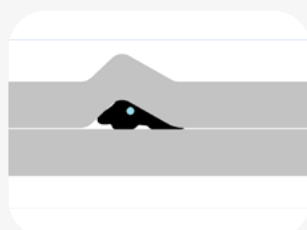

Align spigot and socket, and slide the spigot into the pipe, past the seal.



As the pipes are joined the rubber sealing element is deformed and creates pressure against both spigot and socket resulting in a watertight seal.

STANDARDS AND APPROVALS

- NSF/ANSI 14
- NSF/ANSI 61
- ASTM 2241
- ASTM F477
- NOM-001-CONAGUA
- NMX T-021
- CSA

SIZE CHART

PIPE SIZE (inch)	A (inch)	B (inch)
1-1/2	0,315	0,673
2	0,315	0,673
2-1/2	0,433	0,929
3	0,472	1,012
4	0,512	1,099
5	0,551	1,181
6	0,590	1,264
8	0,669	1,433
10	0,787	1,689
12	0,869	1,854
14	0,944	2,020
16	1,060	2,269
18	1,142	2,444
20	1,210	2,696
24	1,418	3,034

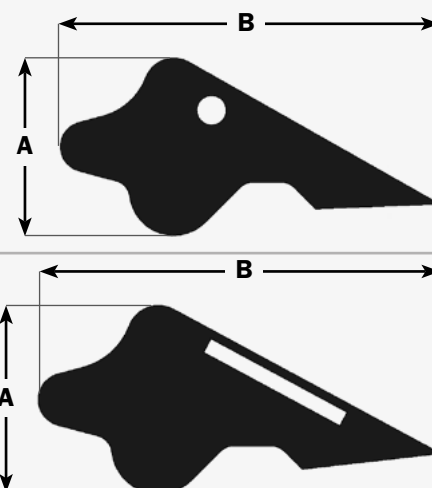

MATERIAL

- Synthetic SBR rubber
- Hardness 55±5 IRHD
- Available in EPDM, Nitrile or other elastomeric material by special order
- Metal reinforcement

Trelleborg proven quality:



TRELLEBORG

WWW.TRELLEBORG.COM/EN/SEALS-AND-PROFILES/