

Trelleborg 165 Integrated Pipe and Manhole Seal

Integrated seal for
concrete storm and
waste water systems

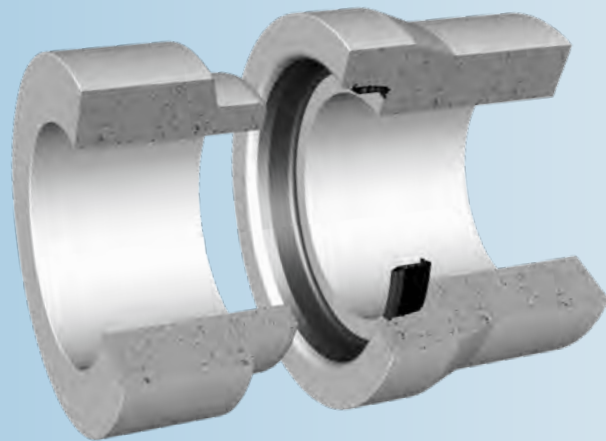

KEY FEATURES & BENEFITS

- cast into pipe or manhole during manufacture
- cannot be displaced during stocking or transportation
- saves time during installation

SEAL DESIGN & FUNCTION

Trelleborg 165 is a one-piece integrated seal for concrete pipe systems. It ensures a watertight seal between pipes, manhole sections and pipe connections to manholes. The seal is cast into the socket during pipe manufacture. This secures the seal in the correct position, minimizing the risk of seal displacement.

Trelleborg 165 is co-extruded, using specially formulated EPDM rubber compounds of two hardnesses to form the perfect seal:

1. The forming part, made of hard rubber (70 IRHD), ensures a secure and accurate joint profile during casting.
2. The sealing part, made of soft rubber (50 IRHD), is a combined lip and compression seal.
3. Holding sections are cast into the concrete during pipe manufacture, securing the seal in the correct position.
4. Slurry lips against the pallet prevent ingress during concrete compaction.

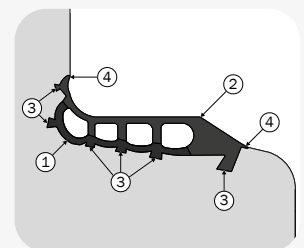

JOINT ASSEMBLY

Check that the socket and spigot are in good condition and free from mud and gravel. Do not use damaged pipes or manhole sections.

Apply lubricant to the spigot. Spread evenly over the entire surface, paying special attention to the front radius of the spigot. Additional lubricant applied to the seal may further reduce the jointing force.

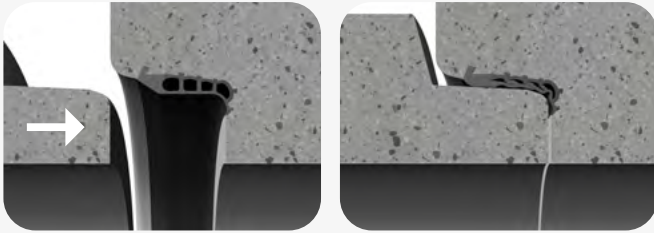

Center the spigot into the socket and push the pipe or manhole sections together. The seal design prevents concrete to concrete contact.

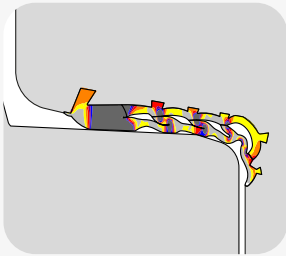

When the pipes or manhole sections are assembled, the rubber sealing element is designed to deform. This creates pressure on both spigot and socket, ensuring a watertight seal.

APPROVALS

- CE-marking
- BSI "Kitemark"
- Swedcert
- Benor

STANDARDS

- EN 681-1
- FBS QR 4060
- ISO 9001

SIZE CHART

PIPE DN (mm)	PROFILE	A (mm)	B (mm)
250 - 300	12	12.4	64.5
300 - 600	14	14.7	72.4
300 - 600	14T	14.6	86.5
675 - 1200	18	18.4	89.2
675 - 1200	18N	18.4	98.3
675 - 1200	18T	18.4	109.2
1200 - 1600	22	22.6	107.1
1200 - 1600	22T	22.9	120.8
1600 - 2500	26	26.5	128.2

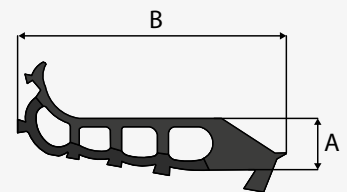

Concrete pipes with Trelleborg 165 seals must be laid in accordance with applicable standards and regulations.

Please contact us for technical advice and joint design recommendations to meet your performance requirements.

MATERIAL

- EPDM
- Hardness 50±5 IRHD (Sealing part)
- Hardness 70±5 IRHD (Forming part)

Trelleborg proven quality:



TRELLEBORG

WWW.TRELLEBORG.COM/EN/SEALS-AND-PROFILES/