

# Liner End Seal

## Technical Specifications

### PURPOSE OF THE PRODUCT

This specification describes the function of the NPC Liner End Seal, its principle of operation, and the component materials that constitute the Liner End Seal and their physical properties.

### PRODUCT APPLICATION

Liner End Seals are designed to seal the raw end of a relined/renewed pipe which has been lined with a cured in place product, and prevent infiltration or exfiltration into or from the end of the liner. They are designed to withstand internal and external pressure of 30 feet (13 psi).

### BACKGROUND

Once a cured-in-place liner has been installed there is a certain amount of shrinkage associated with the installation. This is normal, and generally accounted for by the installer in calculating the length of the liner tube/felt required to renew the host pipe and manage the shrinkage effectively.

Periodically, however, the section of host and renewed pipe adjacent to the manhole is not fully lined, cannot be completely sealed and an end seal is required. NPC – Liner End Seals assure the end of the liner is fully sealed and will not allow infiltration or exfiltration, or root intrusion into the pipe at the sealed end.

### PRINCIPLE OF OPERATION

NPC - Liner End Seals stop leaking at the manhole to liner connection by bridging the joint with a flexible rubber seal and compressing the rubber seal against the inside diameter of the pipe on either side of the joint with expansion bands.

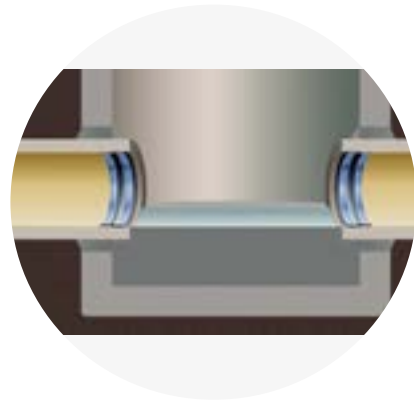

The compressive force providing the seal on either side of the joint is the result of increasing the effective diameter of the stainless steel expansion bands. The patented Slotted Band® is constructed from a single piece of 300 Series Stainless Steel precisely rolled to match the diameter of the CIPP liner.

A specially designed tool is used to expand a high strength stainless steel band outward at either end of the seal. The diameter of the expansion bands are increased and the band is permanently held in the expanded position with an integrated latching mechanism.

This incorporates the patented slotted expansion band and a stainless steel latching mechanism, creating a permanent, mechanical watertight seal. As the band expands the integral latching mechanism progresses from slot to slot, positively locking on each one, until the next one is reached. Once the band has been expanded into place there is an audible click created by the spring/rubber interaction.

## MATERIALS

The NPC - Liner End Seal is manufactured in compliance with the material requirements of ASTM C923-02, consisting of a high-quality, flexible rubber seal and stainless steel expansion bands.



### Flexible Rubber Seal

The Liner End Seal is extruded from a high-grade rubber compound and the ends are joined using a hot, vulcanized splice, making the splice as strong as the rest of the seal.

### Internal Expansion Bands

The Expansion Bands are manufactured from 300 Series, non-magnetic, stainless steel which conforms to the material requirements of ASTM C923-02.

## ASTM C-923 Material Properties

PHYSICAL PROPERTY	ASTM SPECIFICATION	TEST REQUIREMENT
Chemical Resistance 1 N Sulfuric Acid 1 N Hydrochloric Acid	D543, at 22°C for 48 hours	No Weight Loss No Weight Loss
Tensile Strength	D412	1200 psi
Elongation at Break	N/A	35% minimum
Hardness	D2240 (shore A durometer)	5% +/- from manufacturer's specified hardness
Accelerated Aging	D573 70°C for 7 days	Maximum Decrease 15% tensile 20% elongation
Water Absorption	D471, immerse 0.75 by 2 inch specimen in distilled water at 70°C for 48 hours	10% weight increase maximum
Ozone Resistance	D1149	Rating 0
Low Temp. Brittle Point	D746	No fracture at -40°C
Tear Resistance	D624, method B	200 lbf/in.