

Drain Flexrib Manhole Chimney Seal

**Eliminates
Inflow & Infiltration**

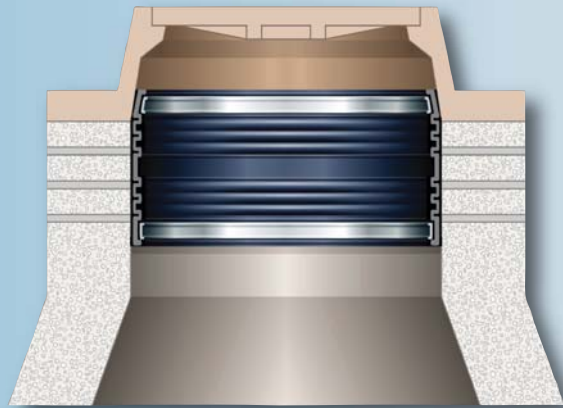

The grade adjustment area of the manhole is the first to suffer deterioration caused by freeze/thaw cycles, traffic loading, thermal expansion and contraction of the surrounding pavement and other external forces.

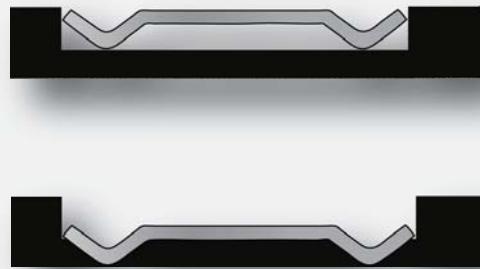

- Creates a watertight seal between the frame casting and top of the manhole cone
- Allows the Seals to move vertically and/or laterally while maintaining a watertight seal
- Made from a premium quality rubber compound and available in four widths.
- Patented Waveband technology creates a more effective seal by concentrating the compressive force of the expansion band. The rubber is "captured" between the band and the concrete.

AVAILABLE WIDTHS:

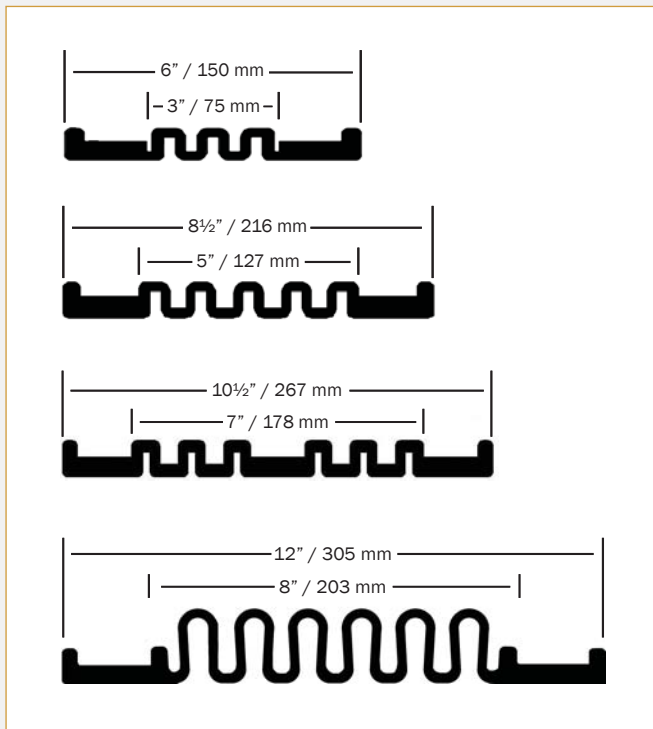

FLEXRIB EXTENSION:

When the adjustment area of the manhole exceeds the range of the available FlexRib Seals, a FlexRib extension may be added to provide an additional 8" / 203 mm coverage.

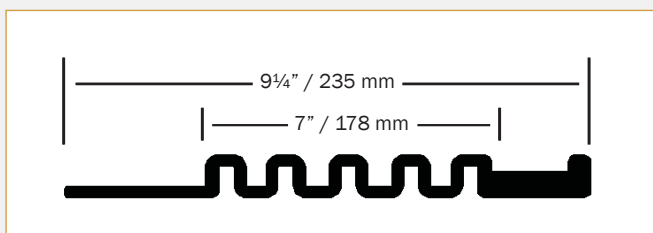

INFORMATION NEEDED TO ORDER:

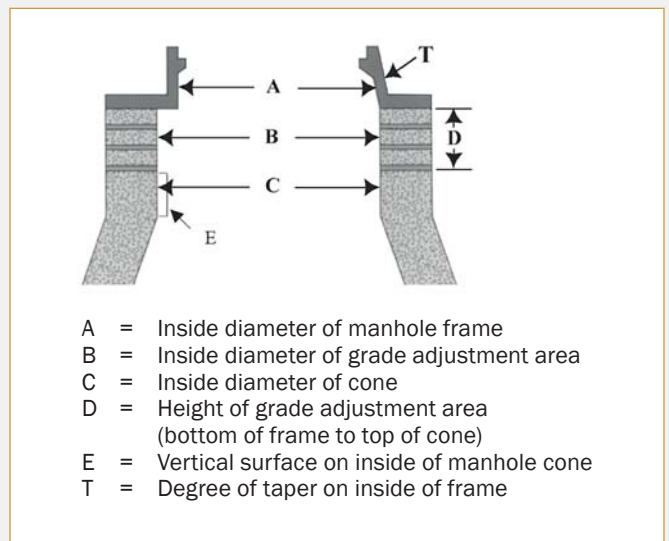

INSTALLATION TOOLS:

MANUAL INSTALLATION TOOL:

Works with a 1" socket or open ended wrench.
Compress seal to 125 N (28 ft. lbs.)
P/N 92003



HYDRAULIC INSTALLATION TOOL:

Force balanced heavy-duty construction develops 1½ tons of force.
Compress seal to 310-345 bar (4500-5000 psi)
P/N 91893



WWW.TRELLEBORG.COM/PIPE-SEALS