



Hawser Hooks for Tandem or Single Point Mooring

Hawser Hooks

Description

This document describes mooring system options that may be installed on board an F(P)SO for Tandem Mooring or for bow mooring to a Single Point Mooring facility.

Trelleborg Hawser Hooks and control systems have been installed in over 100 F(P)SO facilities for Tandem Mooring offloading applications and may include the hawser and hawser winch.

Quick Release Hawser Hooks are generally used as the anchorage points for the mooring hawser's chafe chains and other options can include emergency quick release, load monitoring and a remote central control system.

Additions to the Tandem Mooring may also include a Hawser Storage Winch referred to in Sections 7.

FEATURES

- **Positive locking**, resetting and release operations, with security against inadvertent or accidental release.
- **Load Monitoring** & High Load Warning System designed for ship board operation.
- **Emergency Release**, local or remote release from the Cargo Control Room (CCR) panel.

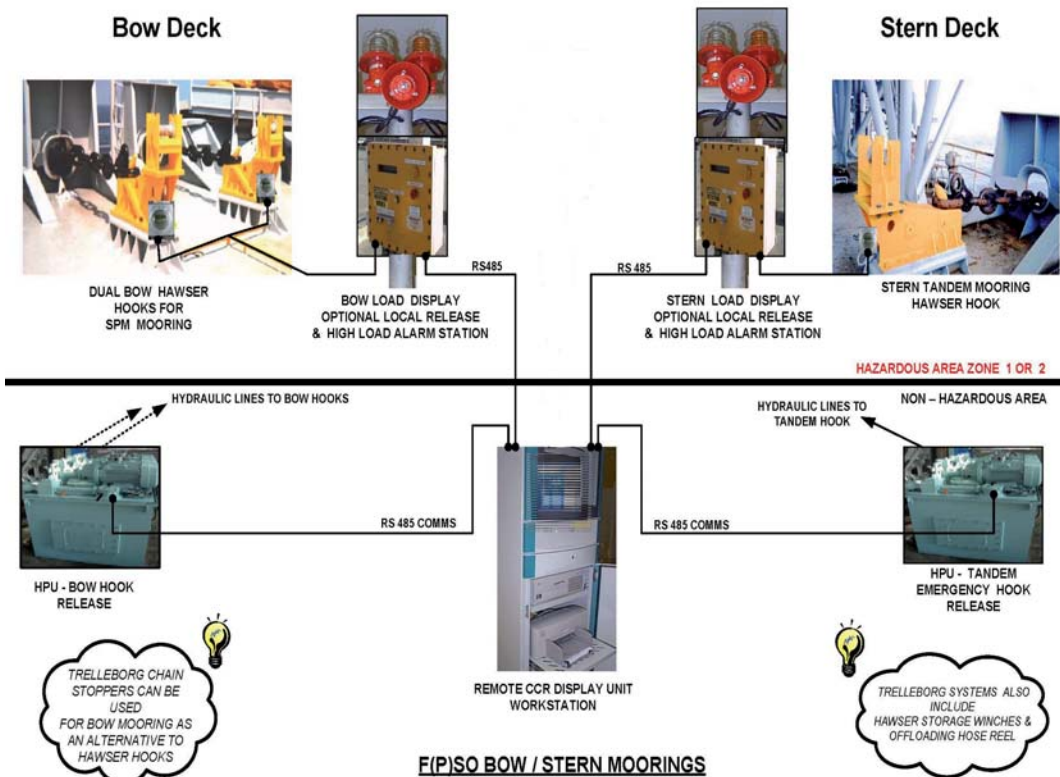

Mooring Requirements: Tandem Mooring & SPM (Ref Note 1)

Ship Size	Number of Hawser Hooks or Chain Stoppers	Minimum SWL (tonnes)
100,000 DWT or less	1 (Ref Note 2&3)	200
Over 100,000 DWT but not greater than 150,000 DWT	1 (Ref Note 2&3)	250
Over 150,000 DWT	2	350

Table 1

Notes:

1. Based on OCIMF MEG 3 & ABS, DNV, BV Class Rules
2. Tandem Mooring: Minimum quantity as shown.
3. For Single Point Mooring applications: ships in this size range may elect to fit two mooring units to ensure full range of terminal acceptance.

STANDARD MODELS

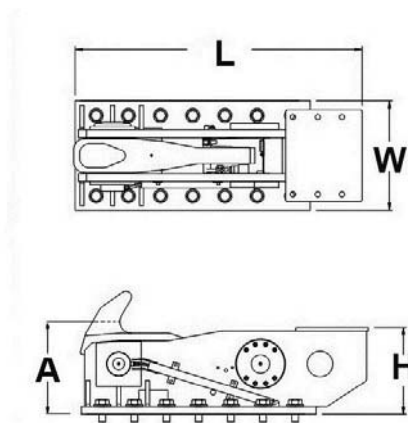
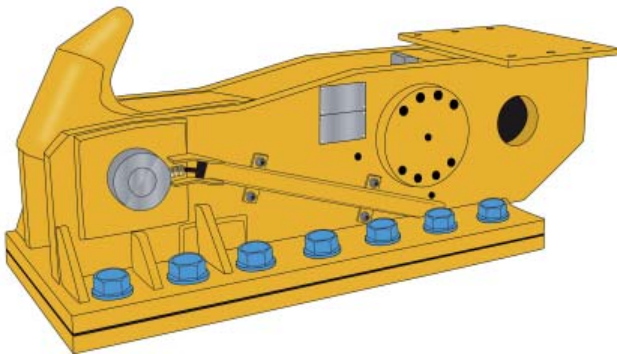

Product Code	Length (L) mm	Width (W) mm	Height (H) mm	Height to Chain Centreline (A) mm	Max. Safe Working Load tonnes	Max. Proof Load tonnes	HD Bolt QTY	Shipping Mass kg
H580	1560	560	540	440	250	313	14 x M42	950
H850	1790	680	540	580	350	550	14 x M56	1650

Table 2

1 GENERAL		
1.1	Application	Tandem Mooring or Bow Mooring to Single Point (SPM).
1.2	Compliance with Class & other Guidelines	OCIMF <i>Mooring Equipment Guidelines</i> (MEG 3) 2000 Appendix E. OCIMF <i>Recommendations for Equipment Employed In The Bow Mooring of Conventional Tankers at Single Point Moorings</i> 2007. DNV, ABS, BV, Lloyds or RINA as applicable
2 HAZARDOUS AREA COMPLIANCE		
2.1	Area classification	The equipment will be supplied with certificates for Hazardous Area Zone 1 or Zone 2 compliance where applicable or as specified.
3 QUICK RELEASE HAWSER HOOKS		
3.1	Design Criteria	Refer to Table 1. For all hawser hooks, yield load is 2 x SWL in accordance with OCIMF, MEG3 Appendix E.
3.2	Chafe Chain Load Position with the Hawser Hook	The chafe chain alignment with the hawser hook is critical, and the following is noted: The elevation of the hawser hook above the deck will determine the position of the fairlead / chock. The chain angles between chock & hook should not exceed the following Horizontal Plane: +/- 5 degrees of centreline Vertical Plane zero to +5 Degrees above centreline
3.3	Weak Links	OCIMF does not recommend weak links in limiting the mooring tension. Refer to <i>Recommendations for Equipment Employed In The Bow Mooring of Conventional Tankers at Single Point Mooring</i> Section 5.3.
3.4	Mooring Connection	The hawser hook will accept an OCIMF standard (open) end link of 76mm chafe chain. Type A or B as per OCIMF MEG3.
3.4	Mounting	Bolt down onto a flat or raised foundation plate (plinth) & set level.
3.5	Underdeck Stiffening	Design assumed by others in accordance with Class Rules.
4 FAIRLEADS AND FOUNDATION STRUCTURE		
4.1	Scope of Supply	Assumed by others unless specified otherwise.
4.2	Design	In accordance with OCIMF MEG3 and Class requirements.
4.3	Chock / Fairlead Type	A closed chock or closed fixed fairlead is to be installed directly in front of each hawser hook Minimum Yield capacity 2 X SWL of Hawser Hook Load position Horizontal +/- 90 degrees of centreline Load position vertical +/- 30 degrees of centreline

5 LOAD MONITORING SYSTEM		
5.1	Load Cells	Trelleborg manufactured load cell installed in each hook Stainless steel construction Calibrated integrally with hooks 0 to SWL Accuracy +/-2% BSL Dual gauged load cells.
5.2	Local Display Unit	A panel mounted display unit with LCD readout of load magnitude and load warnings supplied as standard.
5.3	Remote Display Unit for Load Monitoring	Generally located within the CCR or Bridge to monitor, display and record load and alarm history for each hook Unless otherwise specified CCR is assumed a non hazardous area and assumed to be an air conditioned environment. The Remote Display Unit consists of a 19 inch rack panel 10 U (max) suitable for mounting to a standard 19 inch rack cabinet (cabinet by others unless specified otherwise). Includes PC workstation, LCD monitor and operators panel. Functionality: <ul style="list-style-type: none"> Setting of load alarm levels for hawser hook(s) Load display and High Load warning Load history and alarm trail for hawser hook(s)
5.4	Load Alarm Station	Optional deck mounted visible and audible alarm station mounted on deck to provide crew with <i>High</i> and <i>High-High</i> load warnings
5.5	DCS Interface	Optional interface allows transfer of data for <i>Reading</i> loads and alarms from the load monitoring system.
6 RELEASE SYSTEMS		
6.1	Manual Release Unit	Hawser hooks can be individually and locally released.
6.2	Emergency Remote Release System	<ul style="list-style-type: none"> Remote Release for Emergency Release is typically hydraulically operated by dedicated Electro Hydraulic Power Unit (HPU) Release panel options can include local push button or remote CCR release. The Release command is to be Operator instigated. Automatic release is not provided. Safety interlocks are installed to prevent accidental or inadvertent release. HPU suitable for Non Hazardous location unless specified otherwise.
6.3	Remote Display Unit for Remote Release	When the Remote Release option is provided the Remote Display Unit within the CCR provides the additional functionality: <ul style="list-style-type: none"> Remote Release command and actuation with safety interlock Hook "Locked" Status display "Failed to Release" notification Emergency Release Release <i>Lock Out</i> facility

7 HAWSER DEPLOYMENT AND STORAGE WINCHES		
7.1	Tandem Winch integration	<p>Hawser hooks can be integrated with Trelleborg Horizontal or Vertical drum hawser winches.</p> <p>Winch options may be designed as:</p> <ul style="list-style-type: none"> Single section drum for hawser only storage <p>Refer to Data Sheet OIM-WNR-02, OIM-WNR-04 & OIM-WNR-06</p>
8 SURFACE TREATMENT		
8.1	Treatment	<p>Class 2.5 Blast to AS 1627.4</p> <p>75 Microns Epoxy Primer</p> <p>125 Microns High Build Epoxy containing MIO</p> <p>75 Microns Polyurethane top coat.</p> <p>Finished Colour Yellow (RAL 1004) unless specified otherwise.</p>
9 POWER AND CABLE REQUIREMENTS		
9.1	Voltage Supply	<p>380 - 440V 60Hz to the HPU</p> <p>220 - 240V 60Hz to the Local Display Unit and CCR remote display</p>
9.2	Control Cable	<p>Interconnecting cable from the CCR assumed to be supplied by others unless specified otherwise.</p> <p>Cable details refer Data Sheet DAM-ISC-02</p>
10 CLASS CERTIFICATION & TESTING		
10.1	Class Certification	<p>The level of Class Certification & testing will be determined for each project and provided in accordance to specification requirements.</p>
10.2	Hawser Hook & Load Cell	<p>The release test is performed at the certified SWL.</p> <p>Proof Load test See Table 2.</p> <p>Load Cell calibration performed with load cell installed within the hook.</p> <p>Load Cell calibration range 0 to SWL</p> <p>Testing by independent third party licensed test facility and Class witness.</p>
10.3	Load Monitoring & Remote Release Instrumentation	<p>A full system instrumentation, monitoring, display and software system test is provided. Factory Acceptance Test (FAT) is in accordance with client approved Trelleborg FAT procedures</p>

11 QUALITY		
11.1	Accreditation	Trelleborg Marine Systems Melbourne ISO 9001 2008 accredited with Lloyds Register.
11.2	Material Traceability	Class Survey and material certificates provided for all structural materials
11.3	Inspection and Test Plan (ITP)	Provided with Vendor Post Award documentation package submitted for client approval.
12 DOCUMENTATION		
12.1	Post Award Vendor Technical Package	Submitted for Client review and comment.
12.2	Manufacturing Data Record (MDR)	Manufacturing Data Record (MDR) provided at completion for fabrication, mechanical, materials, electrical certifications, NDT and testing
12.3	Installation Operation & Maintenance Manuals	All Manuals are provided
13 INTEGRATION WITH OTHER TRELLEBORG SYSTEMS		
13.1	Hawser Deployment and Storage Winches	Hawser hooks can be integrated with Trelleborg hawser winches. Refer to Data Sheet OIM-WNR-04, OIM-WNR-05, OIM-WNR-06.
13.2	Vertical Drum Tandem Mooring Winch with Hook	Hawser winch with vertical storage drum in built hawser hook, as an alternative to horizontal drum winch Refer to Data Sheet OIM-WNR-02 & OIM-WNR-06
13.3	Offshore Docking System	A GPS based system for mooring and station keeping at a Single Point Mooring (SPM) or for Shuttle Tanker position monitoring. Refer to Data Sheet OIM-DAS-01

Trelleborg Marine Systems' commitment to continuous product improvement means that we reserve the right to upgrade and modify equipment and systems without notice as technological and operational parameters demand.

For Further information, please contact:

Trelleborg Marine Systems Melbourne Pty Ltd
 Virginia Park, 9 South Drive, 236-262 East Boundary Road
 East Bentleigh, Victoria 3165
 Australia
 Tel: +61 (0) 3 9575 9999, Fax: +61 (0) 3 9575 9900
 Website: www.trelleborg.com/marine
 Email: mooring@trelleborg.com

