

Bollards

PRODUCT MANUAL





Bollards

At Trelleborg, we understand that reliable port infrastructure is crucial for your operations. That's why we've designed and engineered a range of seven bollard styles to provide the perfect solution for your port applications.

Our bollards are engineered and manufactured from premium grade cast steel, providing superior service life and resistance to impact.

We offer safety critical bollards, anchoring, and fixing solutions tailored to your exact specifications.

Our comprehensive guide provides detailed information about our full range of solutions, where we adopt a whole system approach encompassing application engineering, detailed design, manufacturing and testing, verification, installation support, and maintenance.

Take a Smarter Approach to port operations with Trelleborg.

Contents

Bollards

Introduction	2
Bollard Range and Technical Information	5
Types of Bollards	6
A Whole System Approach to Bollard Performance	13
Bollard Manufacturing Data Record (MDR)	14
Application Engineering	15
Detailed Design	21
Manufacturing and Quality Control	26
Installation, Operation & Maintenance	31
Appendix : Bollard Types Imperial Units	33
Additional Information	41

A smarter approach at every stage

CONSULTATION

Consultation from the earliest project phase to ensure the optimum fender systems and marine technology solutions are specified, with full technical support from our global offices.

CONCEPT

Conceptual design in your local office – with full knowledge of local standards and regulations, delivered in your language – for optimized port and vessel solutions.

DESIGN

Concepts are taken to our Engineering Center of Excellence in India where our team generates 3D CAD designs, application-engineering drawings, a bill of materials, finite engineering analyses and calculations for both our fender systems and marine technology solutions.

MANUFACTURE

Our entire product range is produced in our state-of-the-art manufacturing facilities located strategically, allowing us to maintain complete quality control at every stage of the production process.



TESTING

Across our entire product range, stringent testing comes as standard at every step in our in-house manufacturing process. We ensure that lifecycle and performance of our entire product range meets your specifications, and more.



INSTALLATION

Dedicated project management, from solution design through to on-site installation support. We design products and solutions considering ease of installation and future maintenance requirements.



SUPPORT

Local support on a truly global scale, with customer support teams all over the world. And this service doesn't stop after a product is installed. You have our full support throughout the entire lifetime of your project, including customized training programs, maintenance and onsite service and support.



THE FUTURE

Deploying the latest in smart technologies to enable fully automated, data-driven decision making that optimizes port and terminal efficiency. At Trelleborg, we're constantly evolving to provide the digital infrastructure our industry increasingly needs.



When you choose Trelleborg, we ensure your expectations will be met, through a truly comprehensive end-to-end service – retaining vigilance and full control at every stage.

Bollard range and technical information



Trelleborg bollards are available in a variety of popular shapes and sizes, with our standard range made of cast steel and designed to suit most berths, docks, and jetties.

The use of high-quality materials makes it simple to repair minor defects, ensuring that Trelleborg bollards have a long and trouble-free service life.

FEATURES

- High quality cast steel as standard
- Strong and durable designs
- Low maintenance
- Wide range of line angles available
- Standard and custom anchors available

Designing mooring systems is a crucial aspect of port infrastructure, with significant safety implications. These systems must ensure that vessels can be safely secured while facilitating secure cargo handling operations and minimizing the risk of operational downtime.

Trelleborg bollards are designed with optimal geometry and anchor layout, which is achieved through a combination of finite element techniques and actual product testing. Our design process also takes into consideration the safe working load of the bollard in relation to its breakload, ensuring that the bollard remains stable and safe for mooring even when used at full working load capacity.

A critical step in mooring design is the mooring analysis, which should be carried out by qualified engineers in accordance with international and local standards such as BS6349 series, EAU:2012, ROM 02.90, the OCIMF Mooring Equipment Guidelines MEG4, and the UFC 4-159-03.

When selecting bollards for a mooring system, it is essential to choose those with a safe working load that is equal to or greater than the mooring design calculation loads. Additionally, it is important to evaluate the mode and type of failure to reduce the risks to the vessel or infrastructure.

Tee Bollard

FEATURES

- General purpose applications up to 300 tons
- Suitable for rope angles from -15° to $+75^\circ$

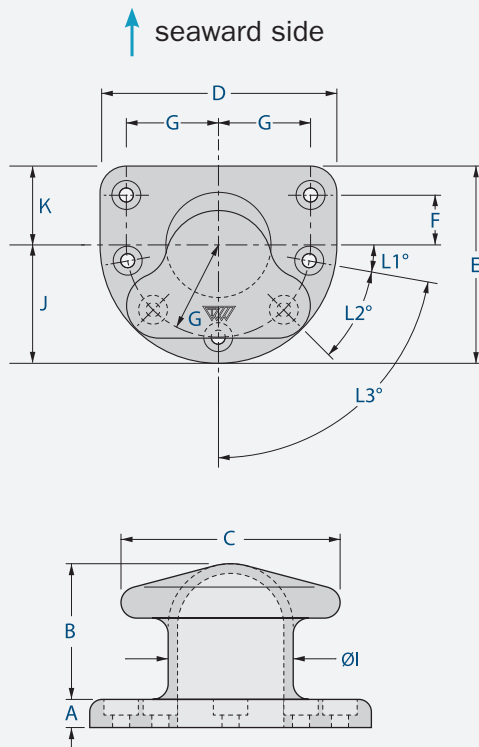
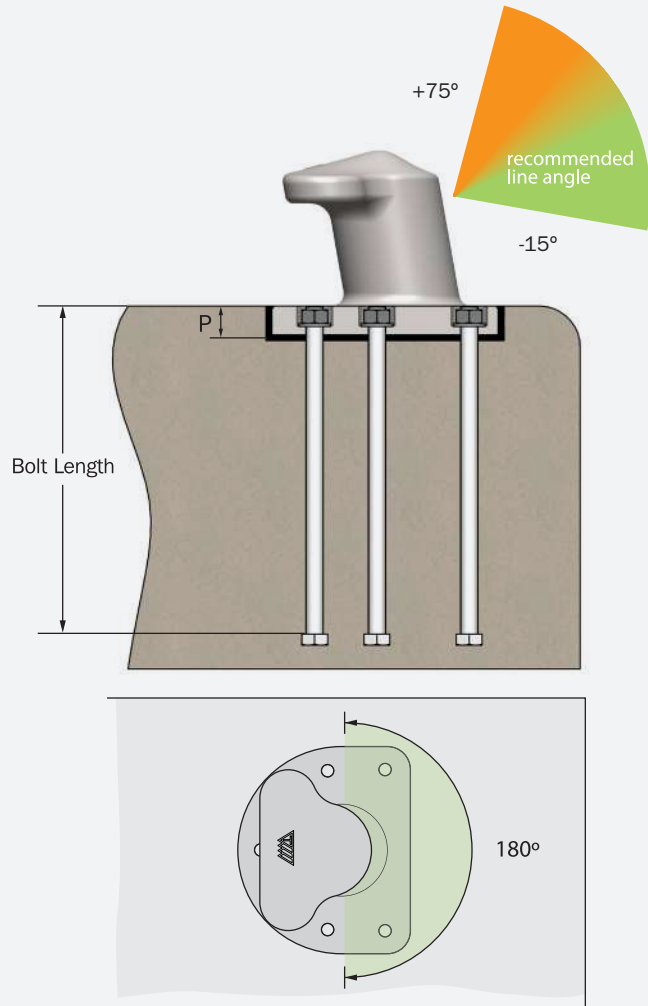

DIMENSION	BOLLARD CAPACITY (Tonnes)									
	15	30	50	80	100	125	150	200	250	300
A	35	38	48	50	60	65	70	80	100	100
B	235	255	350	380	410	410	435	500	610	670
C	330	350	470	540	525	600	640	740	890	980
D	410	450	640	640	790	850	900	1000	1090	1200
E	335	375	540	550	640	700	750	850	915	925
F	80	100	150	160	175	175	200	225	250	200
G	155	175	250	250	325	325	350	375	425	475
ØI	150	200	260	260	300	310	325	375	430	500
J	205	225	320	320	395	425	450	500	545	600
K	130	150	220	230	245	275	300	350	370	325
L1°	30°	30°	30°	15°	10°	10°	10°	0°	5°	23°
L2°	-	-	-	45°	40°	40°	40°	36°	34°	26°
L3°	60°	60°	60°	-	80°	80°	80°	72°	68°	52°
Bolts	M24	M30	M36	M42	M42	M48	M48	M56	M64	M64
Bolt Length	500	500	500	800	800	900	1000	1000	1375	1550
P	50	53	63	65	75	80	85	95	115	115
Quantity	5	5	5	6	7	7	7	8	8	10

P = bollard base recess mounting depth
= hold-down bolt protrusion height

[units: mm]

For imperial units refer to appendix

Horn Bollard

FEATURES

- General purpose applications up to 300 tons
- Suitable for rope angles from -15° to +75°
- Two lines may share a single bollard (subject to bollard capacity)

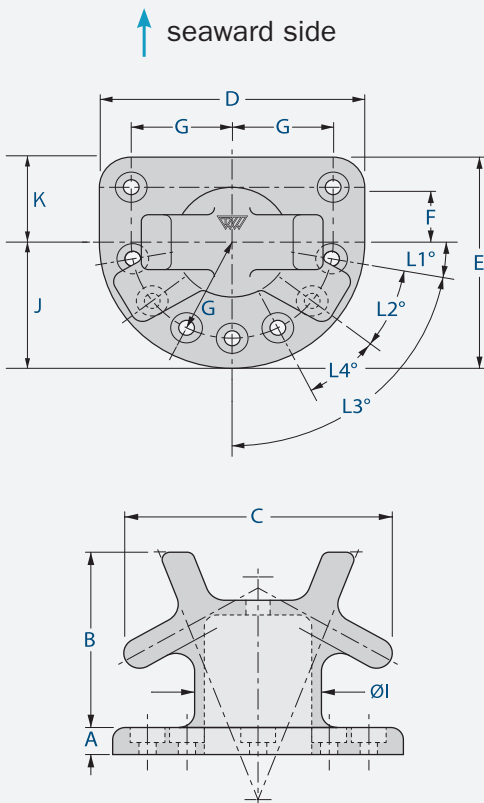
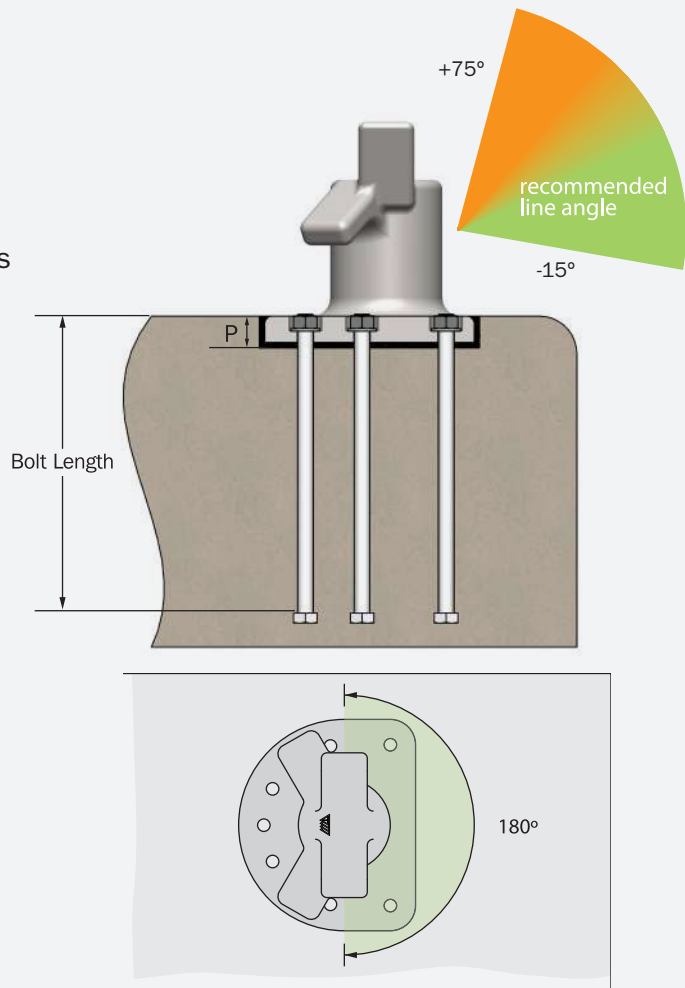

DIMENSION	BOLLARD CAPACITY (Tonnes)									
	15	30	50	80	100	125	150	200	250	300
A	35	35	50	50	65	70	70	80	90	100
B	370	410	500	520	570	595	595	660	690	850
C	410	450	600	600	670	700	770	820	855	975
D	410	480	640	650	800	820	920	1000	1000	1200
E	335	405	540	560	650	670	770	850	850	925
F	80	100	150	160	175	175	200	225	225	200
G	155	175	250	250	325	325	350	375	375	475
ØI	160	200	260	260	275	300	325	350	375	450
J	205	240	320	325	400	410	460	500	500	600
K	130	165	220	235	250	260	310	350	350	325
L1°	30°	30°	30°	15°	10°	12°	10°	0°	0°	23°
L2°	60°	60°	60°	45°	40°	39°	40°	36°	36°	26°
L3°	-	-	-	-	80°	78°	80°	72°	72°	52°
L4°	-	-	-	-	40°	39°	40°	36°	36°	26°
Bolts	M24	M30	M36	M42	M42	M48	M48	M56	M64	M64
Bolt Length	500	500	500	800	800	900	1000	1000	1375	1550
P	50	50	65	65	80	85	85	95	105	115
Quantity	5	5	5	6	7	7	7	8	8	10

P = bollard base recess mounting depth
= hold-down bolt protrusion height

[units: mm]

For imperial units refer to appendix

Kidney Bollard

FEATURES

- General purpose applications up to 200 tons
- Suitable for rope angles from -15° to $+60^\circ$
- Suitable for warping operations

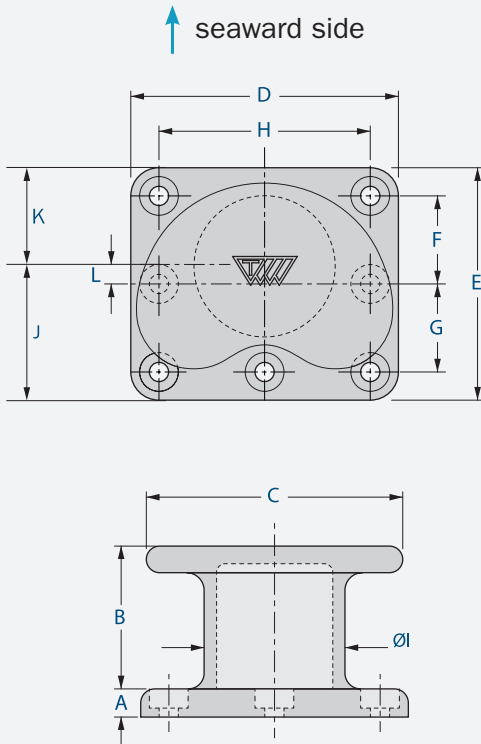
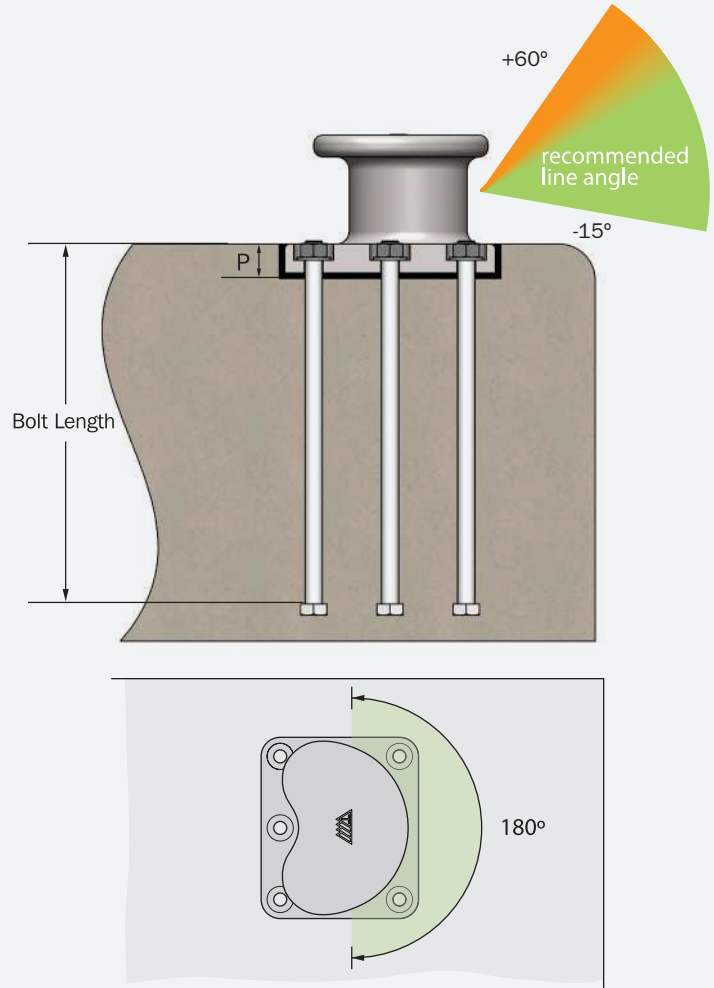

DIMENSION	BOLLARD CAPACITY (Tonnes)							
	15	30	50	80	100	125	150	200
A	30	35	45	65	65	70	80	82
B	210	230	270	285	310	333	380	395
C	300	345	450	470	500	550	630	700
D	320	360	540	560	590	680	760	1000
E	320	360	540	460	490	580	660	850
F	-	-	-	-	175	210	250	300
G	-	-	-	-	175	210	250	300
F+G	220	260	400	320	350	420	500	600
H	220	260	400	420	450	520	600	750
ØI	160	200	260	260	270	300	350	380
J	160	180	270	280	315	360	415	535
K	160	180	270	180	175	220	245	315
L	-	-	-	-	70	70	85	110
Bolts	M24	M30	M36	M42	M42	M48	M48	M56
Bolt Length	500	500	500	800	800	1000	1000	1000
P	45	50	60	80	80	85	95	97
Quantity	4	4	4	5	7	7	7	7

P = bollard base recess mounting depth
= hold-down bolt protrusion height

[units: mm]

For imperial units refer to appendix

Cleat Bollard

FEATURES

- General purpose applications up to 35 tons
- Suitable for rope angles from -15° to $+60^{\circ}$
- Suitable for small wharves or jetties and marinas
- Two lines may share a single bollard (subject to bollard capacity)

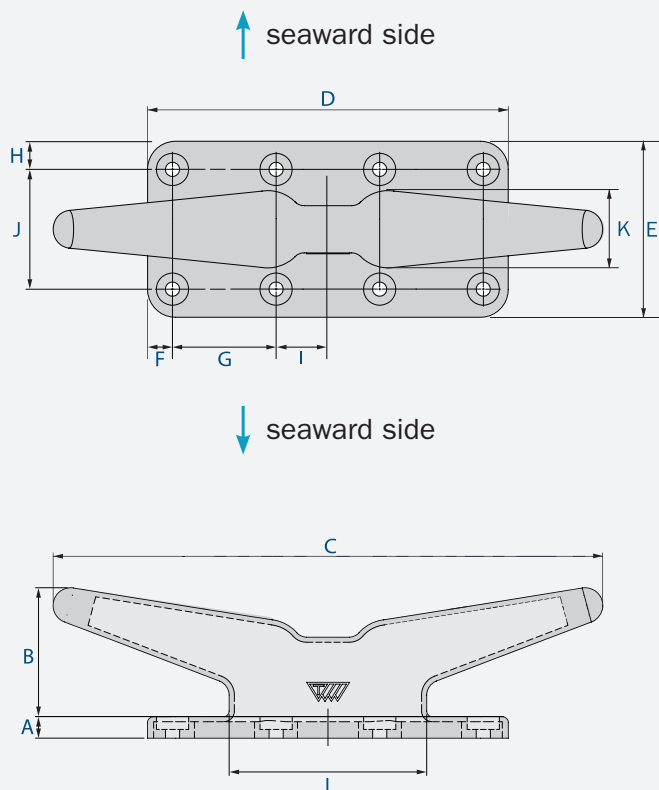
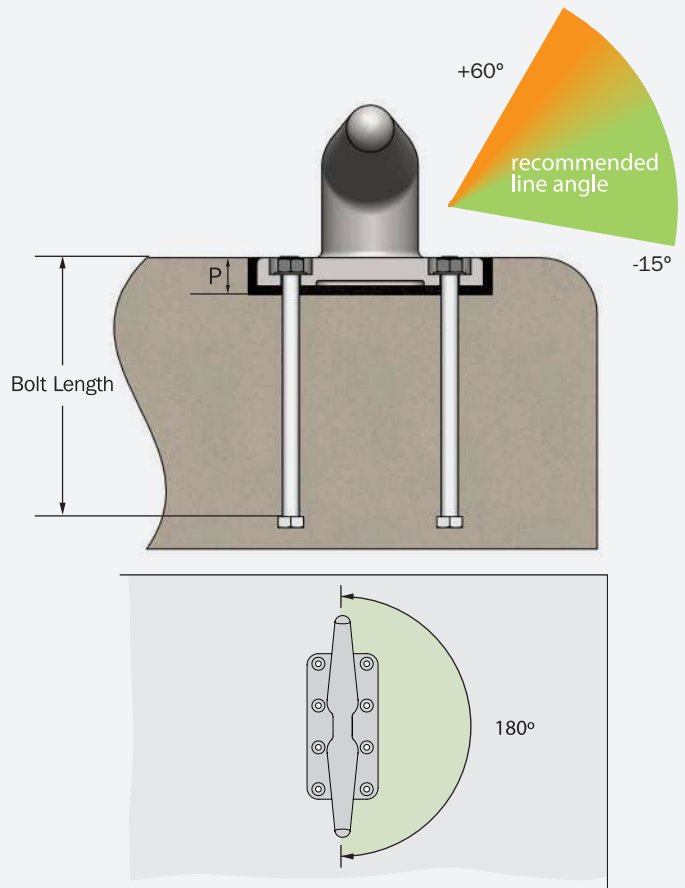
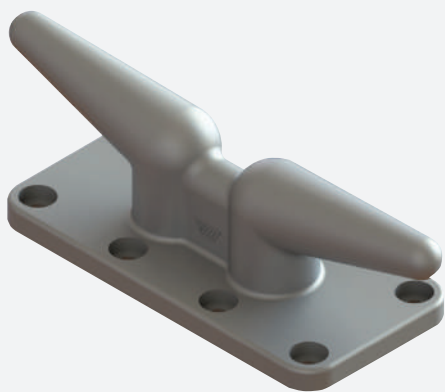

DIMENSION	BOLLARD CAPACITY (Tonnes)				
	15	20	25	30	35
A	25	30	38	40	45
B	168	185	214	254	272
C	510	665	810	960	1120
D	410	510	610	660	840
E	220	280	310	310	400
F	40	50	50	45	60
G	165	205	255	190	240
H	40	50	50	45	60
I	0	0	0	95	120
J	140	180	210	220	280
K	90	110	130	150	170
L	235	280	325	370	430
Bolt	M20	M24	M24	M24	M30
Bolt Length	350	460	460	460	460
P	40	45	53	55	60
Quantity	6	6	6	8	8

P = bollard base recess mounting depth
= hold-down bolt protrusion height

[Units: mm]

For imperial units refer to appendix

Double Bitt Bollard

FEATURES

- General purpose applications up to 200 tons
- Suitable for mooring multiple lines (subject to bollard capacity)
- Concrete filled (optional)
- Suitable for rope angles from -15° to +60°

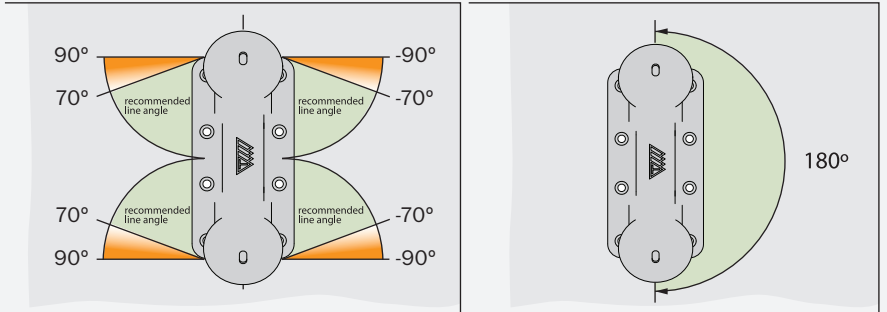
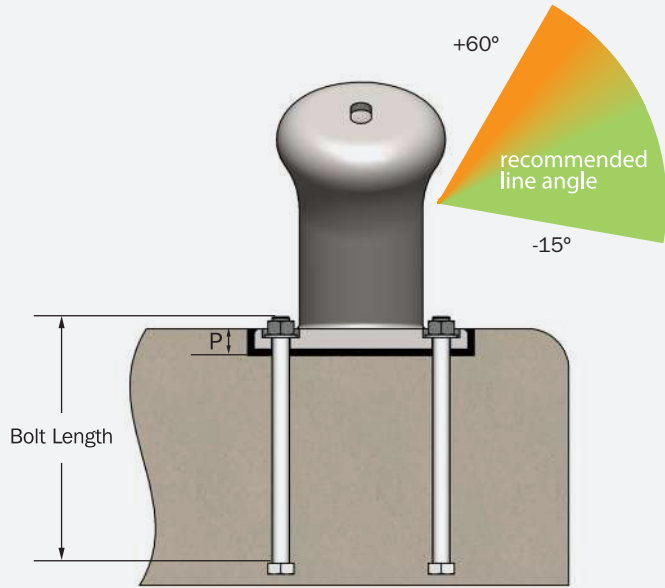

Allowable mooring line angle shown is applicable when mooring line is secured on one bitt of the bollards

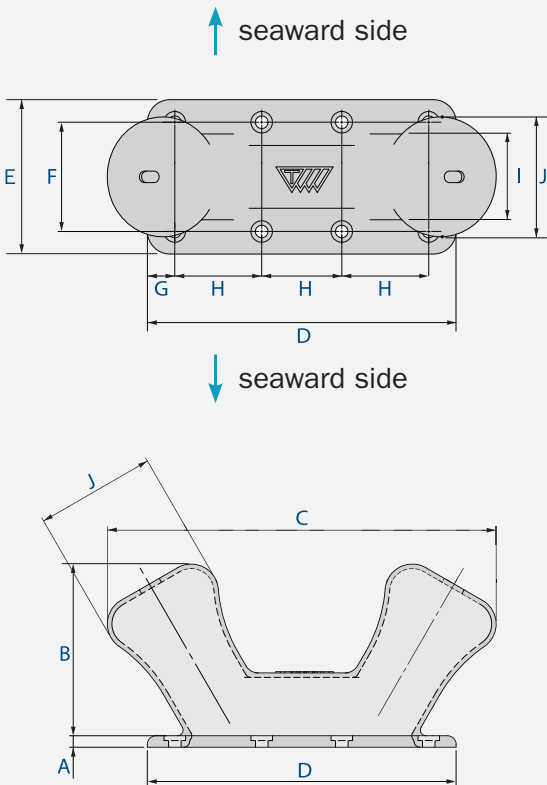

DIMENSION	BOLLARD CAPACITY (Tonnes)							
	20	30	50	75	100	125	150	200
A	16	22	25	35	45	48	48	55
B	290	350	409	510	600	700	750	840
C	650	769	908	1130	1305	1510	1650	1830
D	540	610	720	870	1020	1170	1270	1430
E	280	310	360	440	520	590	640	720
F	190	220	270	330	390	440	490	530
G	45	45	45	55	65	75	75	95
H	150	180	210	190	223	255	280	310
I	130	160	190	230	270	310	340	360
J	173	230	260	330	370	430	480	520
Bolt	M20	M24	M30	M36	M42	M42	M48	M56
Bolt Length	300	300	450	500	600	750	850	1070
P	31	37	40	50	60	63	63	70
Quantity	8	8	8	10	10	10	10	10

P = bollard base recess mounting depth
= hold-down bolt protrusion height

[Units: mm]

For imperial units refer to appendix

Single Bitt Bollard

FEATURES

- General purpose applications up to 200 tons
- Suitable for rope angles from -15° to +75°
- Two lines may share a single bollard (subject to bollard capacity)
- Concrete filled (optional)



↑ seaward side

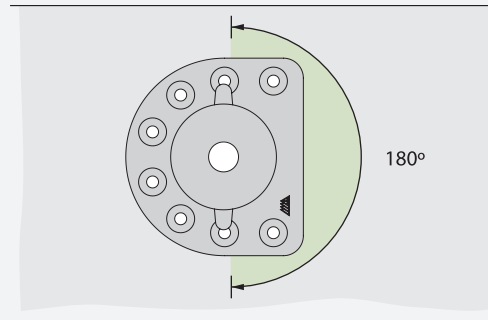
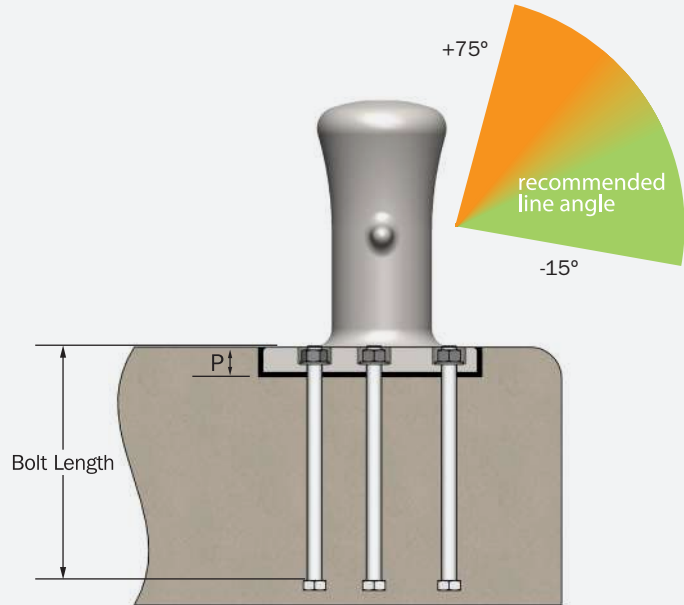
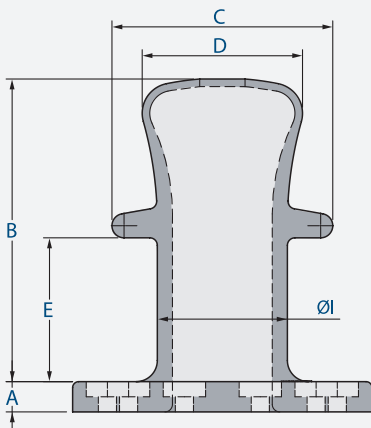
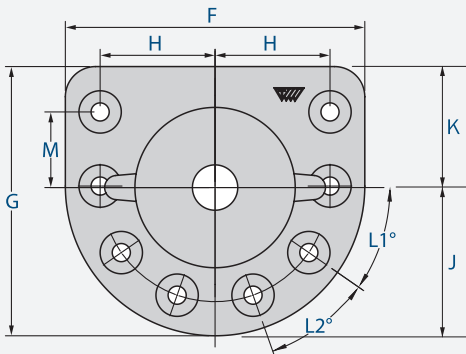

DIMENSION	BOLLARD CAPACITY (Tonnes)							
	15	30	50	75	100	125	150	200
A	30	45	55	60	65	75	80	90
B	373	495	644	743	793	850	904	1005
C	260	325	450	460	510	600	620	710
D	210	245	340	350	375	410	420	490
E	145	160	260	287	325	365	380	465
F	360	420	530	650	760	825	900	990
G	315	380	480	580	685	740	810	890
H	130	160	205	250	290	313	345	380
ØI	150	185	240	250	280	310	330	390
J	180	210	265	325	380	410	450	495
K	135	170	215	255	305	330	360	395
M	75	120	155	180	215	230	255	280
L1°	50°	24°	13°	13°	5°	4°	5°	35°
L2°	-	66°	50°	49°	43°	44°	44°	35°
Bolt	M24	M30	M36	M42	M48	M48	M56	M56
Bolt Length	400	500	600	600	750	900	1000	1000
P	45	60	70	75	80	90	95	105
Quantity	4	5	6	6	7	7	7	8

P = bollard base recess mounting depth
= hold-down bolt protrusion height

[Units: mm]

For imperial units refer to appendix

Pillar Bollard

FEATURES

- General purpose applications up to 200 tons
- Suitable for rope angles from -15° to $+60^{\circ}$
- Suitable for warping operations
- 360 degree horizontal line angle use
- Can be utilized from all sides of jetty

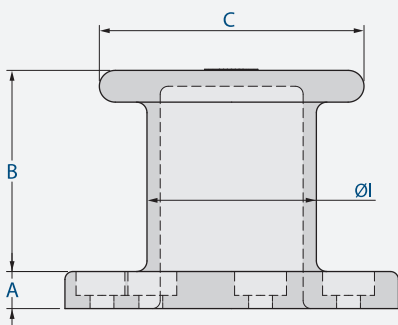
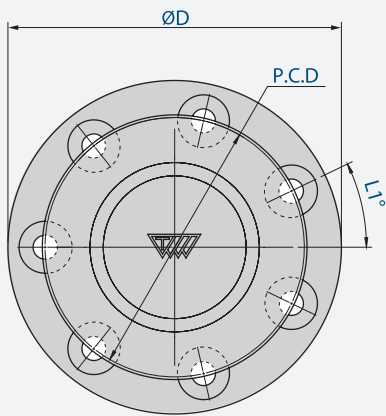
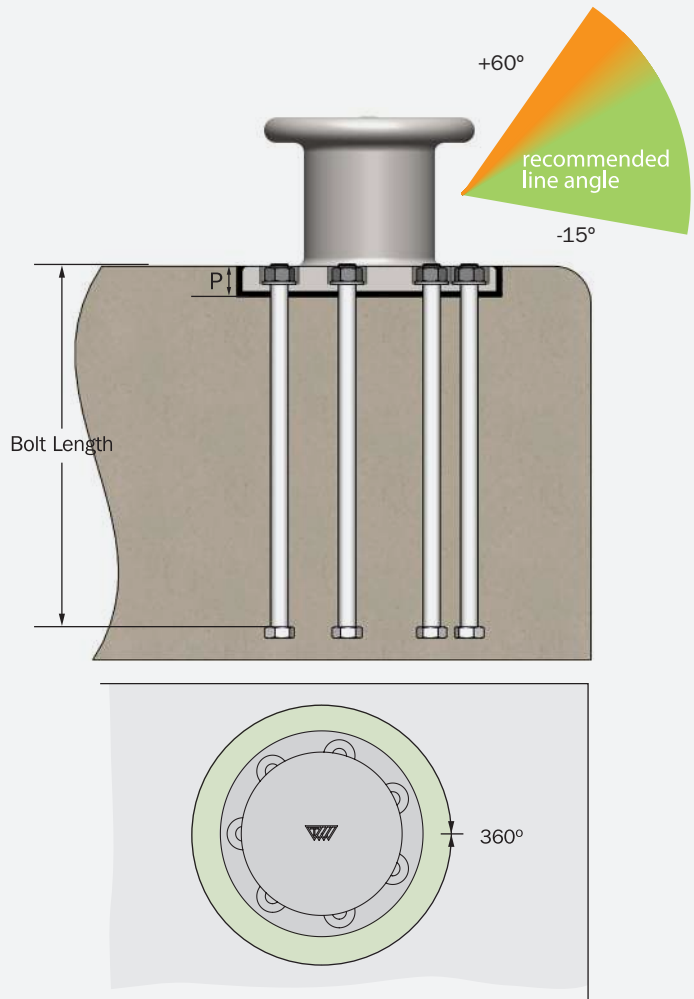

DIMENSION	BOLLARD CAPACITY (Tonnes)							
	10	15	30	50	75	100	150	200
A	20	25	35	40	45	50	55	65
B	155	240	255	296	365	395	430	450
C	200	290	390	430	440	520	630	690
ØD	270	420	500	580	630	700	800	900
P.C.D	190	300	365	450	490	550	600	700
ØI	125	180	240	270	270	300	350	400
L1°	-	-	-	26°	26°	26°	-	-
Bolt	M20	M24	M36	M36	M42	M48	M56	M64
Bolt Length	350	400	550	800	1000	1000	1000	1000
P	35	40	50	55	60	65	70	80
Quantity	4	4	4	7	7	7	8	8

P = bollard base recess mounting depth
= hold-down bolt protrusion height

[Units: mm]

For imperial units refer to appendix

A whole system approach to bollard performance



At Trelleborg, we take a whole system approach to bollard performance, which includes application engineering, detailed design, manufacturing and testing, as well as installation and maintenance. By incorporating advanced materials into our bollard design, we offer a product that sets new benchmarks for quality and functionality. We employ meticulous foundry selection to ensure precise casting processes and an extensive inspection test plan to guarantee the quality and reliability of our bollards. Our bollards are subjected to rigorous testing and verification to deliver exceptional performance while ensuring safety, efficiency, and minimal risks to ports.

APPLICATION ENGINEERING

Our skilled application engineers accurately determine the mooring loads by accessing the load and bollard capacity, performing mooring assessments, and carefully selecting the appropriate bollard for each specific application. This ensures that the bollard can handle the expected loads and perform reliably throughout its design life.

MANUFACTURING AND TESTING

Every aspect of our bollards is meticulously tested through comprehensive testing procedures, including the casting process and control, melting and pour procedures, coupon testing of mechanical, chemical, and physical properties, non-destructive testing, and angular load testing. The comprehensive verification and testing techniques subject each bollard to a rigorous inspection and test plan, ensuring that our bollards meet all international standards and individual project requirements.

Trelleborg offers a comprehensive quality package that includes a thorough and comprehensive set of Manufacturing Data Records (MDR) encompassing all four aspects of the Whole System Approach.

DETAILED DESIGN

The design of the bollard must be meticulously considered, including material grades and specifications. Finite Element Analysis (FEA) is utilized to evaluate the system's performance under various site conditions and throughout its design life. Trelleborg employs a team of skilled engineers to ensure that the design calculations meet industry standards and provide a robust solution for diverse applications.

INSTALLATION AND MAINTENANCE

Proper installation of bollards is crucial for optimal performance. Trelleborg's whole system approach includes consideration of the installation process right from the start. This helps in customization of bollards to suit specific environments, resulting in an extended lifespan and minimized downtime and maintenance requirements. Our services include installation, training manuals, on-site supervision, and maintenance recommendations. With our support, you can maintain continuous operations without any disruptions.

By combining robust materials, state-of-the-art testing, meticulous design calculations and manufacturing processes, we have set a new benchmark in bollard performance, durability, and safety.

Trelleborg's whole system approach - The complete quality package

Trelleborg bollards are the epitome of quality and craftsmanship, designed, engineered and manufactured to the highest standards. When you choose Trelleborg bollards, you can rest assured that you're getting more than just a product. Our comprehensive Manufacturing Data Record (MDR) is a testament to the rigorous quality control measures that we employ at every stage of the process, from design to manufacturing and beyond.

WHAT YOU'LL RECEIVE	DETAILS
Bollard Technical Details	<ul style="list-style-type: none"> ■ Bollard Dimension ■ Bollard Material Details ■ Bollard Mounting Arrangement ■ Bollard Painting/Coating Details
Anchor Details	<ul style="list-style-type: none"> ■ Anchor Dimension Details ■ Anchor Type
GA Drawings	Technical drawings of the bollards and anchors
Bollard & Anchor Calculation	Calculation documents detailing the load-bearing capacity of the bollards and anchors
Bollard FEA (Optional)	Finite Element Analysis documentation for added quality assurance (optional)
Bollard ITP (Inspection and Test Plans)	Inspection and Test Plan documentation detailing the quality control processes
Certificate of Conformance	Certificate of Conformance ensuring compliance with relevant regulations and standards
QA/QC Documentation	Comprehensive quality assurance and quality control documentation including: <ul style="list-style-type: none"> ■ Material Testing Bollard (Physical, chemical and materials properties, NDT, dimensional check) ■ Material Testing Anchor (Properties, chemical analysis, dimensional check) ■ Coating Inspection Reports (Painting bollards, hot dipped galvanization anchors)
Installation, Operation and Maintenance Manual	Detailed instructions on how to properly install, operate, and maintain the bollards
Bollard load test (Optional)	Load test documentation for added quality assurance (optional)

For more information on the technical details, quality assurance processes, and all the other features that make Trelleborg Bollards a safe and reliable choice for marine infrastructure projects, please refer to our complete brochure. If you have any questions or would like to discuss your project with us further, please contact us.

We recommend that these Manufacturing Data Records (MDR) be carefully reviewed by competent individuals prior to handover and acceptance of the bollard to ensure the bollard meets all requirements and provides a safe and long-lasting mooring operation.

Application engineering

At Trelleborg, we are dedicated to creating engineered solutions that are tailored to the needs of modern ports and terminals. An essential aspect of selecting the right bollard for your mooring system is understanding the load requirements of the bollards. To ensure utmost safety, it's important to collaborate with a qualified engineer and conduct a comprehensive mooring analysis that determines the actual mooring line loads as well as necessary load rating of the bollard.

Our team of experienced engineers is equipped to provide application-specific engineering support to ensure our bollards are optimally designed for your unique mooring requirements. With a focus on safety, reliability, and performance, we work with our customers to provide solutions that meet your exact needs.

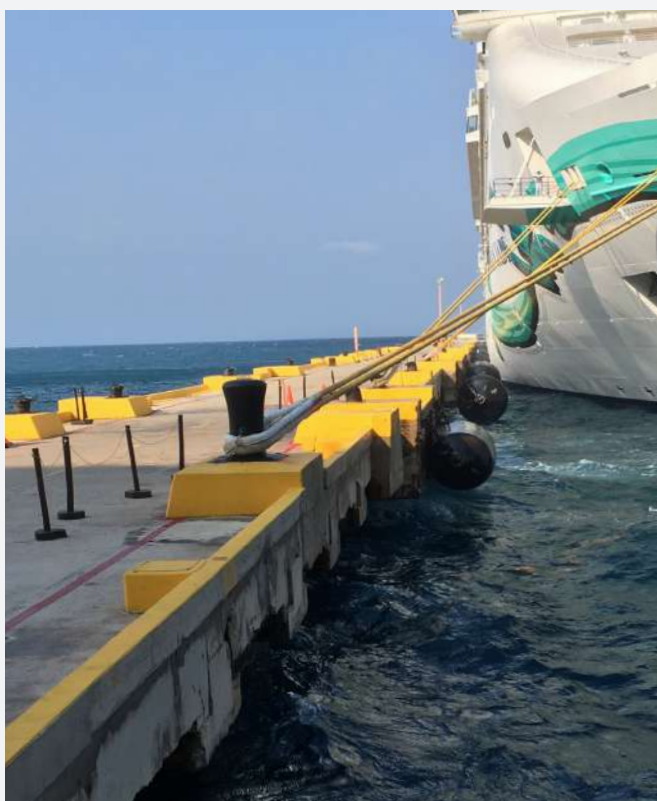

LOADS AND BOLLARD CAPACITY:

Bollards should be selected and arranged according to local regulations or recognized design standards.

The BS6349-4 suggests five methods to determine the probable maximum loadings on a bollard:

I Elastic analysis

The loads on the bollards should be calculated by treating the mooring lines as an elastic system, using either hand calculation or a computer. The wind and current forces on the vessel should be calculated using the method given in the (national) design codes such as the BS 6349-1, EAU 2012, OCIMF Mooring Equipment Guidelines (MEG4), UFC 4-159-03 and ROM 02-90.

For calculation by hand, the system should be simplified by assuming that the longitudinal forces are resisted by the spring lines and the transverse forces at the bow and stern by the bow and stern breasting lines respectively. The mooring ropes should be assumed to have the same characteristics, and account should be taken of the lengths and angles of the mooring lines.

I Simple share loads

An alternative method of calculating the loads on each individual mooring point is to assume that if the berth has six mooring points then one-third of the total transverse force on the vessel is taken by any one mooring point, and the mooring point should be designed for this force at normal working stresses. The longitudinal forces should be assumed to be resisted entirely by the spring line mooring points. If the berth has only four mooring points, then one-half of the total transverse force on the vessel should be assumed to be taken by any one mooring point.

I Working line loads

For vessels less than 20.000t displacement or for particular vessels using specified mooring ropes and mooring pattern the bollards should be designed at normal working stresses for a force equal to the minimum breaking loads of the ropes.

I Computer simulation

A Dynamic Mooring Analyses (DMA) is recommended for berths where vessels are subject to significant wave forces, or where the interaction between the vessels and the waves is significant.

I Notional bollard load capacity

For preliminary designs of continuous berths, if there is insufficient data to carry out the method described above the BS6349-4 suggest to consider:

TABLE 5 MOORING POINT LOADS FOR GENERAL CARGO VESSELS AND BULK CARRIERS

Vessel displacement t	Mooring point load t
20 000 up to and including 50 000	80
Above 50 000 up to and including 100 000	100
Above 100 000 up to and including 200 000	150
Above 200 000	≥ 200

NOTE Storm bollards may be used in the mooring pattern. These are typically > 250 t in capacity.



MOORING LOADS

To select appropriate bollards for a mooring system, it's important to consider the various sources that contribute to loads on moored vessels. These sources include wind, tidal current, wave action, water level and draft changes, operation and movement at berth, ice accumulation, vessel motion, and the weight of the vessel itself. Accurately assessing these factors is necessary to determine the correct type, size, and number of bollards required.

It's also important to ensure that the mooring analysis is conducted in compliance with local regulations and requirements.

Mooring loads should be calculated where possible. The BS6349-4, EAU:2012, UFC 4-159-03 and the ROM 0.2-90 provide guidelines for determining the mooring loads. In the absence of information, the following table derived from the ROM 02-90 (table 3.4.2.3.5.8 & 3.4.2.3.5.15) can be used as an approximate guideline.

DISPLACEMENT (TONNES)	APPROX. BOLLARD RATING (TONNES)
Up to 2,000	10
2,000 ~ 10,000	30
10,000 ~ 20,000	60
20,000 ~ 50,000	80
50,000 ~ 100,000	100
100,000 ~ 200,000	150
Over 200,000	200

In areas where high winds, strong currents or other challenging loads are expected, it is recommended to increase the bollard capacity by at least 25%.

During the design process, the following factors should be taken into consideration:

- Mooring patterns
- Changes in draft due to loading and unloading
- Wind and current forces
- Swell, wave and tidal forces
- Hydrodynamic forces from passing vessels
- Vertical movements of the vessel
- Types, sizes, and angles of mooring lines
- Ice forces (where applicable)

MOORING LINES

For optimal bollard usage, it is recommended by the BS6349-4 (10.3) that bollards are designed to have a maximum of two attached lines, unless a longer neck has been specially designed to accommodate three.

Different types of mooring lines can be used in the mooring pattern, including:

- **Breast lines:** These lines secure the vessel to the quay and should be positioned as perpendicular as possible to the vessel's longitudinal axis.
- **Spring lines:** Used to minimize vessel motion along the quay, spring lines should be aligned as parallel as possible to the vessel's longitudinal axis.
- **Head and stern lines:** Included in the mooring pattern to supplement breast and spring lines.
- **Additional mooring lines:** Sometimes, additional lines may be necessary to assist with berthing or maneuvering a vessel, for example when the vessel needs to be moved alongside the quay.

MOORING LINE ANGLES

Determining the optimal angles for mooring lines is typically done as part of a thorough mooring analysis. To ensure safe and efficient mooring, it's important to keep mooring line angles within appropriate limits.

The ROM 0.2-90 (3.4.2.3.5 b2)** recommends adhering to the angles specified in the following table. Trelleborg bollards are designed to accommodate horizontal angles up to 360° and vertical angles up to 75°, providing the flexibility needed to accommodate a wide range of mooring configurations.

SUGGESTED LINE ANGLES (BS6349, ROM 0.2-90)	
Head & stern lines*	45° ± 15°
Breast lines*	90° ± 30°
Spring lines	5 - 10°
Vertical line angle (α)	<30°

*Relative to mooring angle

Please contact Trelleborg if your mooring application involves expected line angles exceeding the values provided in the table. Such situations may require additional design checks to assess the anchorages and concrete stresses.

(**) The BS6349-4 suggest that the vertical angles are small as practicable and preferably not greater than 25° to the horizontal.

The mooring arrangement and mooring line angles should consider the vessel's freeboard as well as the positions of fenders and other quay furniture to avoid any incidents where mooring ropes could cause damage to quay furniture.

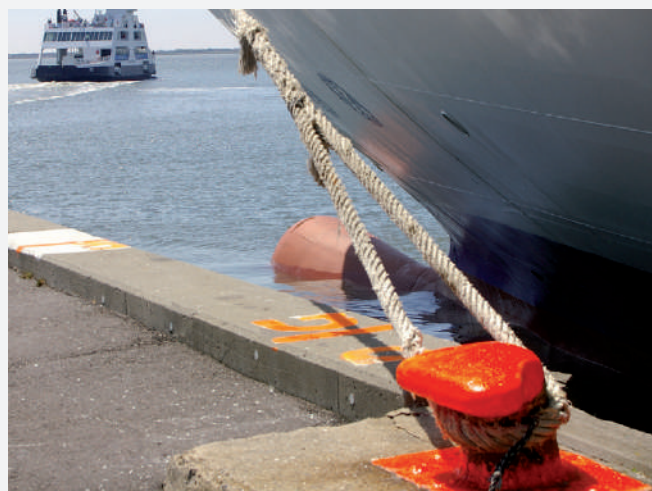

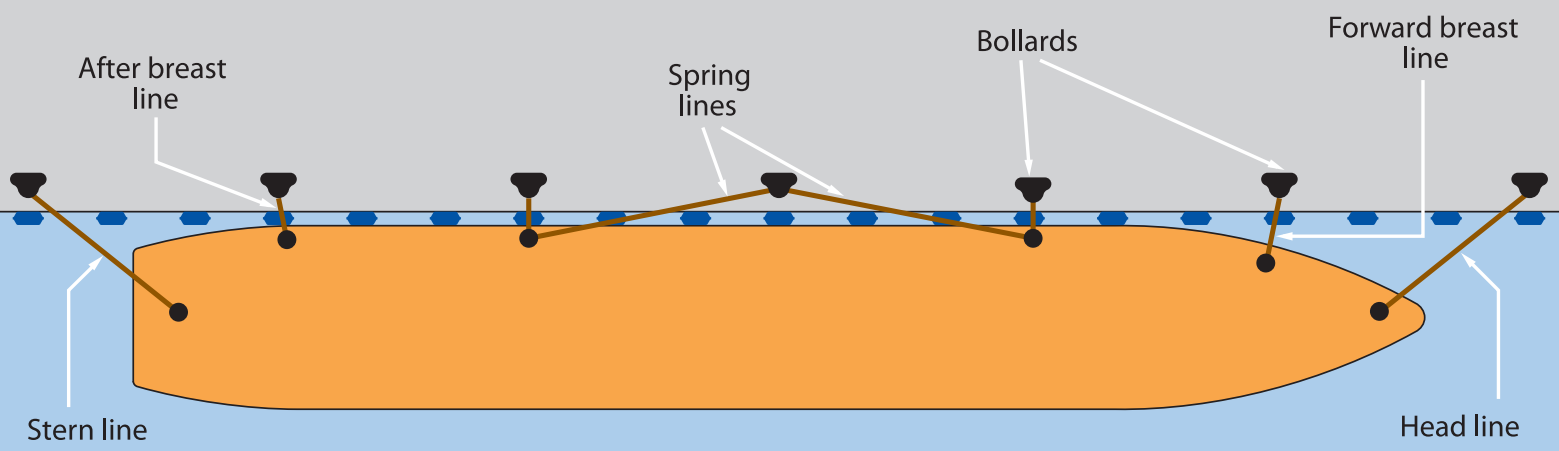
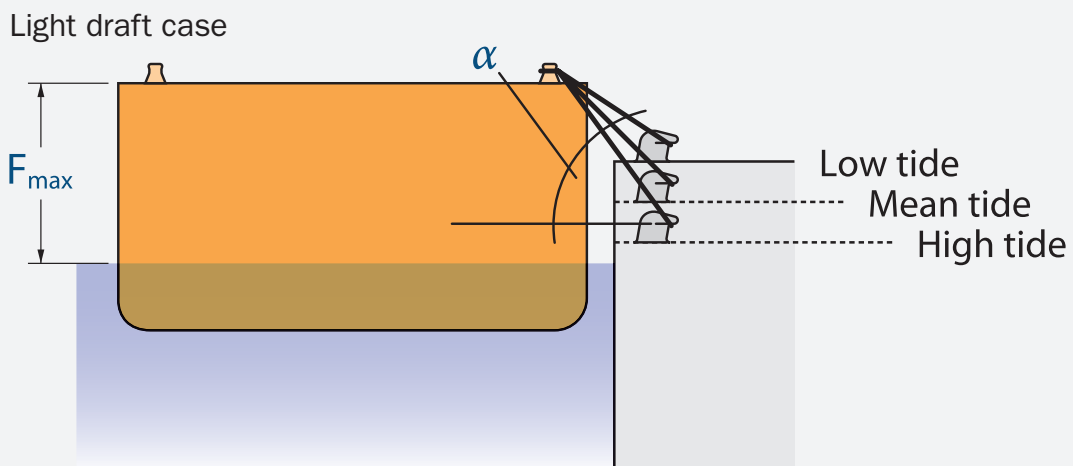
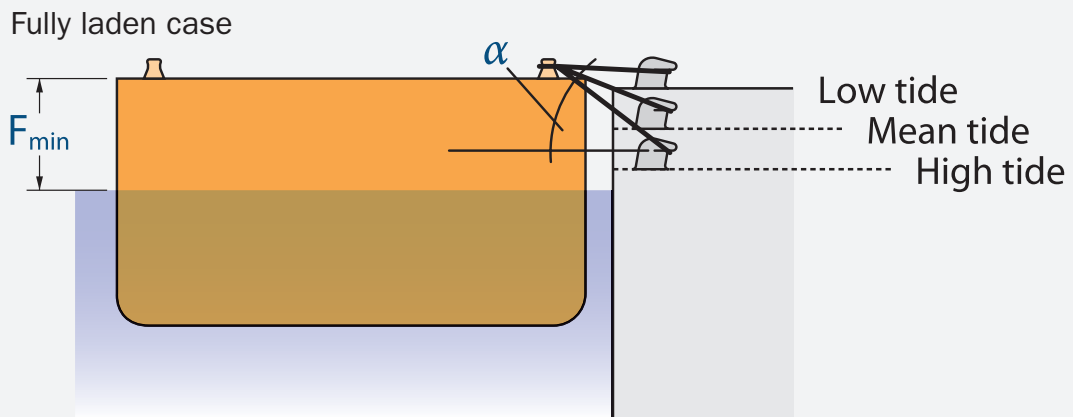

BOLLARD SPACING

To ensure effective mooring, it is generally recommended that bollards be placed at intervals of 15 to 30 meters along a continuous quay (as per BS6349-4 and ROM 02-90). For island berths, the mooring points should be positioned within 35 to 50 meters from the berthing line of the largest vessel (as per BS6349-4 and ROM 02-90).

It is important to note that mooring lines should be long and limited in number to ensure optimal safety and stability. The ROM 02-90 guidelines recommend against using mooring line lengths less than 30 meters.

BOLLARD TYPE:

Bollards are available in a range of designs and capacities to suit all mooring applications. Trelleborg offers commonly used bollard types including T-Head, Horn, Kidney, Double Bitt, Single Bitt, Cleat, and Pillar. The type of bollard required should be selected based on factors such as the required working angle, capacity, and location, among others.

In addition to size and design, bollards are characterized by their material grade and mooring capacities. Durability is also a major factor to consider when choosing a suitable bollard, as regular maintenance by end-users is often necessary. Trelleborg bollards are engineered with a wear allowance of 2 mm, ensuring their full strength throughout their entire service life without compromising on safety.

For specific information and technical specifications, please refer to Trelleborg's Bollard Whitepaper.

BOLLARD MATERIAL

Trelleborg Bollards are supplied in Cast Steel as to the EN10340 standard (G24Mn6) or as per the ASTM A148 standard (Grade 105-85). Other materials and other standards including Spheroidal Graphite Iron can be provided upon request.

For operations in arctic regions cast steel grade G24Mn6 is recommended.

For more information or support through selecting bollards for your specific applications, please contact Trelleborg Marine and Infrastructure.

COATING SELECTION:

High performance epoxy or other specified paint systems can be applied in a range of colors and thicknesses to provide a protective coating tailored to your application. The ISO12944 standard specifies a variety of coating options, including high performance epoxy, zinc oxide primer, and uncoated Category C5 is recommended to be considered for bollards. Bollards are also available and supplied hot dip galvanized (HDG) and high strength stainless steel on special request.

BOLLARD HOLD DOWN BOLTS

Bollard hold down bolts are a safety critical component of the overall bollard system. Trelleborg system included a standard set of hold down bolts based on a standard anchoring situation:

- Grade 8.8 hot dipped galvanized hold down bolts
- Anchor layout as per Trelleborg brochure
- Concrete capacity 40 MPa, non-reinforced

Bolt heads, nuts and other components be recessed to prevent snagging of mooring lines and improve overall design life.

We also offer bespoke anchoring solutions that can be tailored to match existing bolt patterns or design constraints, ensuring a seamless integration with your current infrastructure. We provide options for resin anchors with through-type holding bolts, high-strength anchors, and the flexibility to accommodate various concrete capacities.

SMART SOLUTIONS

For situations where load monitoring can contribute to the port's efficiency or safety, Trelleborg's Smart Bollard can be considered.

For more information on Smart Bollards, please contact Trelleborg Marine and Infrastructure.

SUPPLIER QUALIFICATIONS

Bollards play an important role in ensuring the safety of vessels during mooring operations, and they should be regarded as highly engineered products manufactured and tested in accordance with the relevant standards. Therefore, when selecting a bollard supplier, it is crucial to ensure that they have the necessary engineering capabilities, robust manufacturing and quality assurance processes, and a proven track record in supplying high-quality bollards.

A reliable bollard supplier should be able to demonstrate that their products are designed and manufactured to meet the required standards and specifications, ensuring that they can withstand the forces exerted during mooring operations, thereby providing safety of your vessels and port infrastructure.

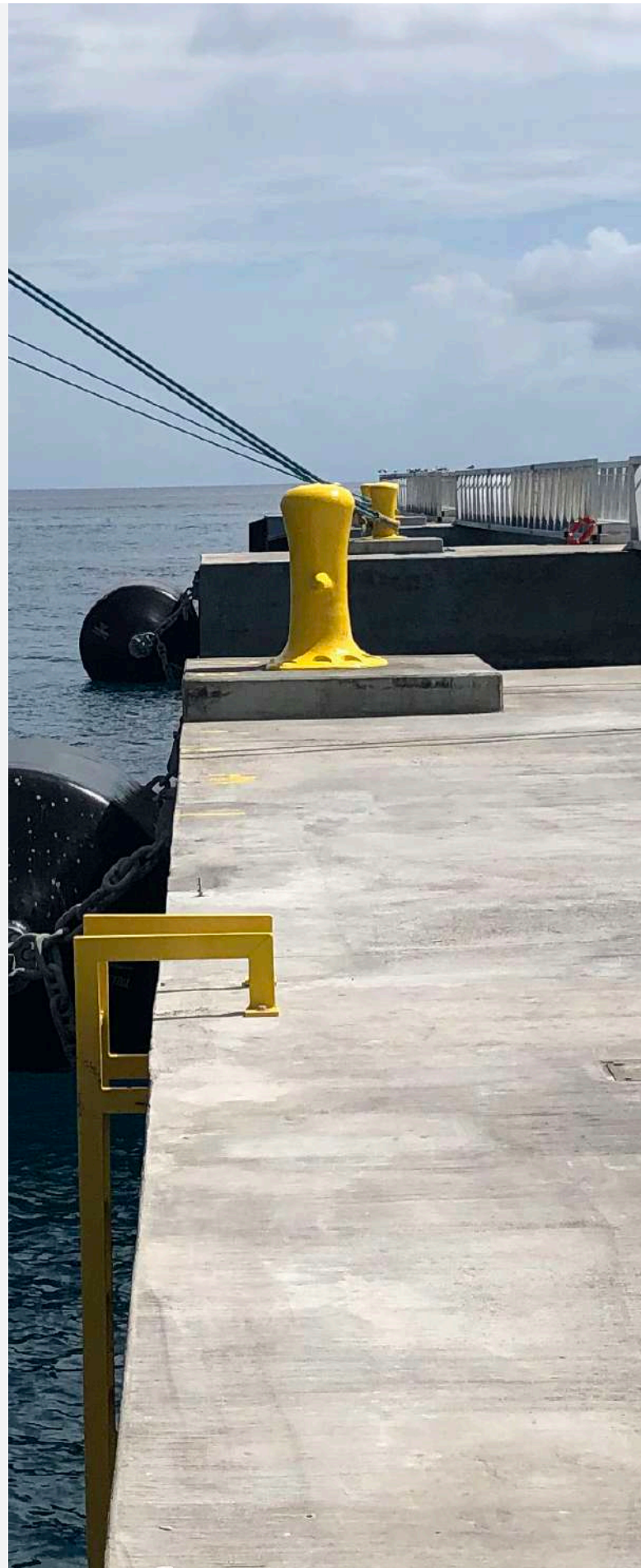

Detailed design

The bollard design must be carefully considered to ensure that the system performs well in given site conditions throughout its design life.

TRELLEBORG STANDARD DESIGNS

At Trelleborg, we offer a comprehensive range of bollards that meet the requirements of various facilities across the globe.

Our standard bollard range has been developed taking into consideration the different regional requirements on function, design codes, painting systems, and other factors, ensuring that you receive the best quality product that caters to your specific needs.

In addition to our standard bollard range, we also offer a range of advanced safety solutions such as the AutoMoor, SmartMoor, and ReadyMoor Quick Release Hooks. These solutions are ideal for instances where enhanced safety features are required.

CUSTOM DESIGNS

Each project is unique, and some clients may require custom-built bollards. That's why we offer bespoke solutions that are designed and delivered to meet your exact specifications. Our team of experts work closely with clients to ensure that all project requirements are met, and the end product is of the highest standard.

DESIGN

We understand the importance of high-quality bollards in ensuring the safety of vessels during mooring operations. The design and construction of bollards must be of the highest standard to support the increasing loads of larger ships and prevent breakage.

As a safety product, the structural strength, stability, and anchoring of the bollards are meticulously engineered to ensure optimal performance. Our bollards consist of several major components, including the barrel, head, anchors, and base plate, which are designed to withstand the forces generated during various loading scenarios.

Our methodology for designing bollards involves performing assessments of the forces acting on these components in different loading scenarios. This ensures that the bollards are designed to meet the specific requirements of each project and can provide reliable and robust mooring solutions.



The Trelleborg standard bollard range is designed to meet most commonly used design codes in Marine Engineering. Our design considers that the Safe Working Load (SWL) meets the various codes in relation to required design checks and partial factors.

Designs are typically based on the following codes:

STANDARDS	CODE NO.	DESCRIPTION
Eurocode	EN1990:2002+A1:2005	Basis of structural design
	EN1993-1-1:2005	Design of steel structures
	EN1993-1-8:2005	Design of joints
British Standard	BS6349-1-2:2016	Maritime structures: General code of practice for assessment of actions
Australian Standards	AS4100:2020	Steel structures
	AS/NZS1170:2002	Structural design actions: General principles
US Standards	AISC	Steel construction manual

Design verification based on other codes can be made upon request.

We place a high priority on ensuring the reliability and safety of our bollards. In addition to meeting the design requirements of various codes, our bollards have a break load factor of approximately 3, depending on their size and type. If you require more information about the break load capacity of our bollards, please contact us.

FINITE ELEMENT ANALYSIS (FEA)

Finite Element Analysis (FEA) is used to verify the manual calculations in order to study different failure modes and to perform fatigue analysis of bollards. Trelleborg validates its design using FEA in conjunction with actual in-house testing to validate the FEA's reliability.

FATIGUE ASSESSMENT

The design of Trelleborg bollards goes beyond withstanding the maximum design load. It also takes into account the impact of cyclic mooring loads from wind and waves, which, if not considered, could lead to fatigue failure of the bollard. Trelleborg's bollard design is specifically tailored to address fatigue concerns. If there is a

need for a project-specific fatigue assessment, Trelleborg can perform it, given that clear data on loads and frequencies over time are provided. For more information, please contact us.

MECHANICAL ABRASION ALLOWANCE

The design of the bollards must be carefully considered to ensure that they perform well in the given site conditions throughout their service life.

Despite the highest attention to selecting and application of the paint system, both the bollard paint system and the bollard itself are subject to wear and tear over time.

To reduce the effects of wear and tear and extend the service life of the bollards, maintenance as per our Bollard Operation, Installation, and Maintenance (OIM) manual is required. However, we recognize that even with proper maintenance, corrosion of the bollards cannot be completely avoided.

At Trelleborg, we take a proactive approach by considering a 2 mm mechanical abrasion allowance in the wear areas of our bollards, in addition to the code design requirements. This means that during its service life, the Safe Working Load (SWL) of the bollard is fully met even with abrasion up to 2 mm.

MATERIALS

Trelleborg offers a range of cast materials for bollards, including ductile cast iron, grey cast iron, and cast steel. As standard, our bollards are made from EN 10340 and ASTM A148 Cast Steel, which offers superior strength, high impact resistance, and ductility. This ensures the bollards can withstand overload situations and provide the necessary structural margin.

EN 10340 is a code specifically intended for structural uses in civil engineering works, making it highly relevant for bollards and recommended by BS6349-1-4 "Maritime works - Code of practice for material".

The table below provides some basic ideas of commonly used material for the bollard casting process.

	Ductile Cast Iron (Spheroidal Graphite)	Grey Cast Iron	Cast Steel
Strength	High strength, but nodularity % affects strength of casting	Low strength	High strength
Impact resistance	Good impact resistance	Low impact resistance	High impact resistance
Chemical composition	No clear details on chemical composition for SG iron in any international standards like ASTM A536, EN 1563 or ISO 1083. Hence, it depends on the capability of the manufacturers to produce the required grade of SG iron that can meet the specified mechanical properties with sound grain structure.	No clear details on chemical composition for grey cast iron in any international standards like ASTM A48, EN 1561 or ISO 185. Hence, it depends on the capability of the manufacturers to produce the required grade of grey cast iron that can meet the specified mechanical properties with sound grain structure.	Clear details available for chemical composition in international standards. Easy to manage manufacturing process to achieve desired mechanical properties.
Ductility	Ductile material, but nodularity % affects the ductility of the product.	Brittle material	Brittle material
Corrosion resistance	High corrosion resistance	Excellent corrosion resistance	Regular maintenance need to reduce corrosion
Manufacturing process	Very stringent/controlled process	Easy	Easy

Trelleborg cast steel bollards with minor defects can be repaired using standard welding techniques and can also be welded down to supporting steel structures for additional reinforcement.

MATERIAL SPECIFICATION

Trelleborg bollards are manufactured to the highest standards. Our standard materials and grades are listed in the table below, but many other options are available upon request.

MATERIAL	STANDARD	YIELD (MPA)	TENSILE (MPA)	ELONGATION (%)	HEAT TREATMENT
G24Mn6 No. 1.1118	EN10340	550	700-800	12	+QT1 (*)
		500	650-800	15	+QT2 (*)
105-85	ASTM A148	585	725	17	As per Clause 5

(*) The heat treatment +QT1 or +QT2 depend on the material thickness which varies from bollard type and size. Please contact Trelleborg for more details.

HOLDING DOWN BOLTS

Holding down bolts are a critical element in the overall design of bollards. At Trelleborg, we design our holding down bolts in accordance with the same safety/SWL design philosophy as for the bollard, using the earlier mentioned design codes.

Details of the holding down bolts are provided on each general arrangement drawing. All bolts are ISO 898-1 Grade 8.8 and hot dip galvanized, with one nut and washer set. It's important to note that

the testing criteria in most fastener codes are not applicable due to the sheer size of the bollard bolts. However, all bolts are tested for chemical and physical properties in accordance with the guidelines mentioned in ISO 898. Alternatively, the hold down bolts can be provided as per ASTM F1554 Gr 105.

Holding down bolts are hot dip galvanized to prevent them from corrosion.

MATERIALS	STANDARDS	GRADES
Anchor Bolts	ISO 898	Gr 8.8
	ASTM F1554	Gr 105
Galvanization	ISO 1461	
	ASTM A123	

In case of installation of bollards on an existing quay, resin anchors might be required. The calculated lengths mentioned for cast-in anchors cannot be applied to resin anchors. In most cases longer lengths are needed for resin anchors as re-bonding occurs between anchor, resin, and concrete. Please contact one of our sales offices in case resin anchors are required.

JETTY DESIGN

The design calculations are based on Trelleborg's standard cast-in anchors design and layout. These calculations are based on a concrete strength of 40MPa, which is commonly used in many new facilities. The pull-out calculations for the anchors depend on various site-specific factors, such as edge distance, concrete grade, amount of reinforcement, and more.

Our standard anchor arrangement, as illustrated in our installation manual and drawings, is sufficient for minimum edge distance and concrete grade C40 (minimum), and supporting calculations can be provided upon request. For any project-specific requirements, please contact our sales offices.

It is important to note that the final design of the jetty, including steel reinforcement, edge distances, shear bracing, and concrete strength, is the responsibility of the jetty designer. Nonetheless, our team can offer guidance and support to help ensure that your project meets the required standards and specifications.

MATERIALS	STANDARD(S)*	GRADE(S)*
Cast Steel	EN10340	G24Mn6
Anchor Bolts (galvanized)	ISO 898 ASTM F1554	Gr 8.8 (galvanized) Gr 105 (galvanized)
Blasting (standard) Blasting (high performance)	"EN ISO 8501-1 NACS no.2"	SA2.5
Paint (standard) Paint (high performance)	ISO 12944	C5 (Very High)

LOW TEMPERATURE APPLICATIONS

Materials get more brittle at low temperatures, which could cause product failure if not correctly addressed in the design and material selection processes. The suitability of applications at low temperatures is tested by performing a Charpy impact test at the required temperatures.

Cast Steel grade EN10340 G24Mn6 +QT2 is suitable for temperatures as low as -30°C and G24Mn6 +QT1 for temperatures as low as -20°C. Grade 8.8 bolts as per ISO 898 are suitable for temperatures as low as -50°C. When operating in cold climates, it is essential to clearly specify the operational temperatures and ensure the supply of the right material grade to guarantee optimal performance.

BREAK-OFF BOLTS/ANCHORS

The magnitude of the loads applied to bollards during mooring operations are significant, and the consequences of a bollard breaking away in an uncontrolled manner can be catastrophic. Unfortunately, due to variations in material properties and tolerances, it is impossible to accurately calculate the actual breakaway load, making it highly unpredictable. The use of unreliable breakaway devices has led to numerous injuries, fatalities, and damage to equipment in the past.

At Trelleborg, we take our responsibility as a manufacturer seriously, and we do not recommend the use of these types of devices. Instead, we believe in providing our customers with high-quality bollards that have been designed and tested to withstand the forces of mooring operations safely.

BOLLARD COATING

The coating selection is in accordance with the ISO12944-5:2019 table C5 “high” or alternative “very high” depending on the project requirements. We recommend an epoxy-based paint system that is easy to maintain and has a proven track record in marine applications. A wide range of colours is available.

MATERIALS	STANDARDS	GRADES	TYPICAL PAINT SYSTEM
Blasting	ISO 8501-1	SA 2.5	
Coating	ISO 12944-5	C5 High	ISO 12944-5 C5.03 Epoxy Primer: 1x 80-240µm Subsequent epoxy coat: 2-4 Total NDFT: 300µm
		C5 Very high	ISO 12944-5 C5.04 Epoxy Primer: 1x 80-200µm Subsequent epoxy coat: 3-4 Total NDFT: 360µm

For compliance to other codes and requirements please contact Trelleborg.

Trelleborg recommends using C5 ‘High’ coating, as per ISO12944, that has a durability range of 15-25 years. Although C5 ‘Very High’ coating provides a longer durability range, a bollard’s paint system is subjected to more wear and tear compared to typical paint applications. Consequently, achieving the full durability range of C5 ‘Very High’ and ‘High’ is unlikely, and repainting the bollard during its service life becomes necessary.

DESIGN DRAWINGS

In addition to considering bollard capacity, it is crucial to carefully review the supplier’s data sheet and drawings when selecting bollards. This will help to determine the bollard’s suitability for installation on the wharf, taking into account factors such as the overall dimensions of the bollard, its footprint, and the minimum edge distance and anchor embedment depth required for safe and effective installation.

By carefully studying these factors, you can ensure that the selected bollards are suitable for your specific application and will provide reliable, long-lasting performance.



Manufacturing and quality control

QUALITY ASSURANCE

At Trelleborg, we take quality assurance and control seriously. Our bollards undergo numerous stringent checks throughout the manufacturing process, which takes place at approved and audited foundries. Our experienced and qualified personnel use several rigorous testing methods to ensure that our bollards are safe for use and meet all necessary requirements and standards.

For customers who require an extra layer of assurance, we offer independent 3rd party witness testing at an additional cost upon request.

Testing methods include:

- Metal casting process & control, melting & pour procedure
- Coupon Test – (Mechanical, Chemical and Physical properties testing)
- Actual Bollard Load Test – Non-Destructive/ Destructive test



Trelleborg bollards are supplied with Manufacturing Data Records (MDR) as standard to highlight the key areas of quality control within Trelleborg’s design and manufacturing process.

A TYPICAL MDR WILL INCLUDE:	
✓	Bollard Technical Details
✓	Anchor Details
✓	GA Drawings
✓	Bollard & Anchor Calculation
✓	Bollard FEA (Optional)
✓	Bollard ITP (Inspection and Test Plans)
✓	Certificate of Conformance
✓	QA/QC Documentation
✓	Installation, Operation and Maintenance Manual
✓	Bollard Load Test (Optional)

*Refer to page 14 for more details

TESTING

Material testing

Material testing is a critical step in ensuring the quality and safety of our bollards. Each foundry heat is accompanied by a destructive material mechanical property test report to verify that the material has met the minimum strength requirement. Non-destructive testing methods such as Magnetic Particle Inspection, Die Penetrant Inspection, or Ultrasonic Testing may also be applied at an additional cost depending on the extent of testing required.

TESTING PROCEDURES

Casting steel is a well-known method for producing high-quality bollards.

The process involves:

1. Metal casting process & control, melting & pour procedure:

Trelleborg supervises the melting, casting procedures, and methods at the pre-production stage to ensure appropriate metal flow and geometrical formation of the bollards.

2. Stamp transfer:

During the casting process, a test piece is integrally attached to the casting or product. Once the casting is completed, the cast number (Heat Number) of the product is transferred onto the test piece for traceability purposes. The test piece is then sent to the lab for testing. A y-shaped test coupon is separated and taken up for mechanical, chemical, and physical testing.



PHYSICAL PROPERTIES

Verification of physical testing is of utmost importance. The selection of material/grade is based on the adequacy calculation, and it is crucial to conduct tensile, yield strength, elongation, and hardness tests to verify the actual mechanical properties.

- Mechanical properties including tensile, yield strength, elongation and hardness (ISO 6892 or equivalent) can be performed on samples cut from the integral test coupon/blocks to determine compliance of the properties specified.
- Charpy impact test (ISO 148-2 or equivalent): can be performed on samples cut from the integral coupon/blocks to measure the amount of energy absorbed during fracture.

All testing is carried out by fully trained and qualified personnel to ensure accurate and reliable results. We offer various methods for performing the actual physical testing of our bollards, depending on your specific needs and requirements.

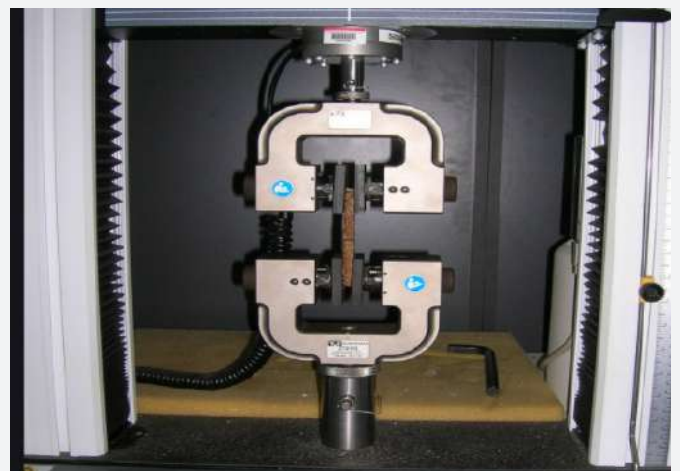

CHEMICAL PROPERTIES

Chemical properties are equally important as the physical properties.

- EN ISO 14284 or equivalent can be further verified from a button sample cut from the integral test piece.

The chemical composition determined from the cast (heat) sample shall meet the requirements of the specifications of the grade selected. Samples

for chemical analysis shall be obtained and prepared in accordance with ISO 14284:2002, standard for the determination of chemical composition. Trelleborg's standard bollard range meets the chemical composition requirements specified in EN 10340:2007 for G24Mn6.

BOLLARD TESTING:

Bollard testing is crucial to ensure the quality and safety of port operations. There are two types of bollard testing: destructive and non-destructive testing. Destructive testing involves physically damaging the bollard to determine its structural integrity. Non-destructive testing, on the other hand, aims to check the quality of the bollard without damaging it. It involves various subtests, including visual inspection, dimensional inspection, ultrasonic testing, magnetic particle inspection, dye penetrant inspection, blasting check and paint/coating check.

Non-Destructive Test (NDT):

1. Visual inspection (ISO 11971 or equivalent): Detects the component for foreign material, cracks, hot tears, cold shut and flaws from casting.



2. Dimensional inspection (ISO 8062-4:2017 Part 4 or equivalent): Dimensions shall be checked against product drawing.



3. Ultrasonic test (ISO 4992-1 or equivalent): Uses reflection and transmission of high frequency sound waves to check for casting defects which cannot be detected visually. It can also be used to measure the wall thickness of the bollard.

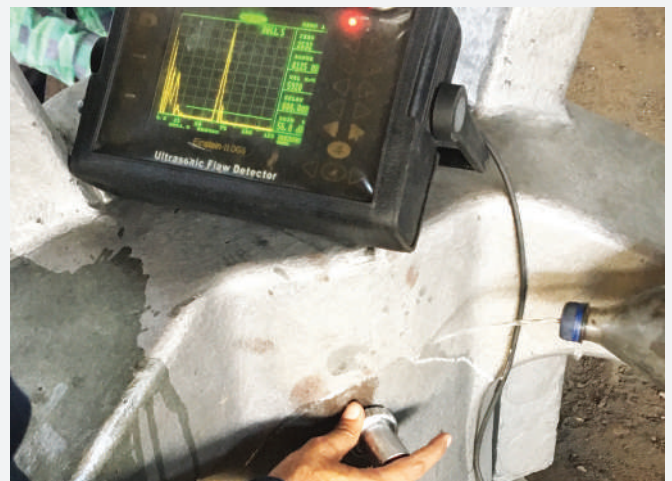

4. Magnetic Particle Inspection (MPI) (ISO 4986 or equivalent): Detects surface discontinuities and defects such as cracks or fractures in the base.

5. Dye Penetrant Inspection (DPI): Used to check surface-breaking defects – porosity, hair line cracks, leakages, fatigue cracks, etc. (can be done if needed and requested).

6. Surface preparation:

Abrasive blasting uses various materials to strip imperfections, paint, rust and other contaminants from a surface. It's an important step in surface preparation, as it cleans a substrate and creates a surface that will hold a protective coating.

Critical steps in quality control of the surface preparation are:

- Degreasing the surface
- Surface cleaning
- Basting
- Dedusting
- Surface profile
- Soluable salts

Please consult Trelleborg for recommended acceptance standards and values.



7. Painting inspection: Coatings are the best way to keep a variety of surfaces safe and prevent corrosion. A marine coating has specific functional properties; therefore, it can provide superior protection to the surfaces to which it is applied, provided that the painting was applied correctly. Trelleborg undertakes various inspections throughout the entire process of coating application to ensure the coating provides superior protection.

The following are the key points of inspection:

- Environment conditions
- Dry film thickness of all paint layers
- Holiday detection
- Adhesion pull off testing
- Visual examination

Please consult Trelleborg for more information on testing standards and acceptance levels.

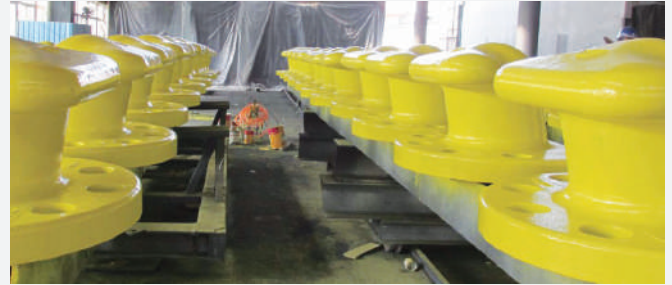

Destructive Test:

Typically, the physical and chemical properties are taken from the integral test coupons or blocks; however, they can also be obtained from the actual bollard body. This testing method involves physically damaging the bollard to determine its structural integrity. Consequently, the bollard can no longer be used for actual applications.



BOLLARD HOLD DOWN BOLTS TESTING:

Recommended testing for the bollard hold down bolts:

- Chemical properties (ISO 898)
- Physical properties (UTS, yield, elongation, hardness and area reduction as per ISO 898)
- Galvanization thickness (ISO 1461)
- Dimensions (including tread)

Chemical properties are typically taken from the raw material, not the bolt itself. Physical properties are tested on the actual bolts (randomly selected from the batch).

The above applies to standard hold down bolts grade 8.8 (ISO 898) and Gr. 105 (ASTM F1554).



BOLLARD LOAD TESTING

Bollards are a vital component in ensuring the safety of vessel, port, and personnel during loading and unloading operations, as well as mooring. The strength of the bollard and its anchors are crucial during these applications to avoid accidents. Load testing bollards is therefore critical to ensure they are fit for use before using them in operations.

Why is load testing critical?

Load testing bollards is essential to ensure that they meet the rated capacity and to eliminate quality control defects. Testing facilities should be used to assess the capacity of the entire system

in all loading directions, verifying the strength of the bollard body to increase safety and reduce downtime during berthing operations. Trelleborg offers tested bollards with third-party certificates to guarantee port operational safety.

Trelleborg can provide a Factory Acceptance Test (FAT) for bollards:

- A Safe Work Load (SWL) test can be done
- A Proof Load test (PL) at 150% of the SWL can be done

These tests will verify the integrity of the bollard body. An on-site load test can be done if needed to check the design integrity of the body and anchors.

Contact Trelleborg for bollard Safe Working Load (SWL) and Proof Load (PL) testing options.

Testing anchors

Once the bollard body is proof load tested, any on-site risk related to the bollard body is eliminated. However, the bollard system is only as strong as its weakest link. Therefore, it is recommended to verify the anchoring system on site as well. Trelleborg can advise separately on cast-in anchor and on-site bollard verification methods to ensure the overall safety and strength of your bollard system.



BOLLARD TESTING MACHINE

Installation, operation and maintenance

INSTALLATION

Bollards must be installed correctly for a long and trouble-free service life. Anchors should be accurately set out with the supplied template. Bollards can be recessed (as shown) or surface mounted. Once the grout has reached full strength, anchors can be fully tightened. Mastic is often applied around exposed threads to ease future removal.

Jetty design

Bollards should be installed according to the unique requirements of each individual jetty for optimal performance. Qualified personnel should assess the suitability of the jetty before deciding on the installation features/process of the bollards. This includes concrete or steel structure reinforcement for additional tensile and shear loads, reduced edge distances, and fastening / anchor-bolt arrangements.

Concrete recess

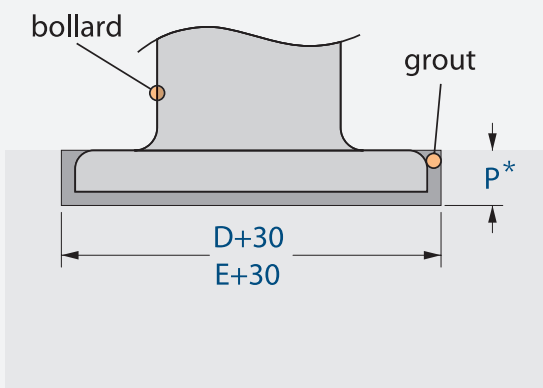

*refer to dimensions tables

Recessing the base prolongs the bollards life expectancy and minimizes the possibility of structural issues as it prevents the bollard from working loose on its bolts or cracking the grout bed - especially relevant for high-use locations. Like all equipment in the marine environment, regular inspection and maintenance is critical to achieving maximum life expectancy.

Trelleborg recommends regular scheduled berth equipment inspection, including bollards. Key items that need to be focused on during the inspection and maintenance include protective coating, grout, technical support, hold down bolts, bollard materials and ropes.



Steel base installation

Bollards can also be installed on a steel base, such as dolphins. Special attention might need to be given to the support structure to accommodate the mooring forces, fixings for the bollard, and flatness requirements of the support structure and the bollard. We recommend contacting your Trelleborg sales office to clarify these requirements.

Hold down bolts

Holding down bolt anchor sets are crucial to bollard performance. Nut or bolt should be tightened manually as per applicable torque guidelines as provided in our Bollard Operation, Installation and Maintenance manual.

Ensuring correct torque settings during installation will optimize the performance of the bollards and hold down bolts. These are critical to be checked during installation.

Grout

Installation and grout filling requires extra care to avoid damage to factory applied coatings. Similarly,

regular inspection and possible repair of grout under and around the bollard is critical to the ongoing integrity of bollard performance. Replacement is recommended should grout be cracked or damaged.

Bollard materials

Regular inspection of the bollard materials is recommended and minor defects can be repaired using standard welding techniques. Trelleborg is happy to assist in providing inspection services on berthing and mooring equipment.

OPERATIONS

The use of steel ropes on bollards is not recommended. Steel ropes will damage the coating system significantly more than synthetic ropes but more over steel ropes will even wear down the cast steel body.

Contact Trelleborg if steel ropes are being used during mooring operations with bollards.



MAINTENANCE

Visual checks on hold down bolts should be undertaken during regular maintenance to ensure no loosening of bolts has occurred.

Protective coating

Bollards are supplied with a protective coating. A high-performance epoxy coating is typically applied, but alternative systems can be used upon request. Despite the care that is taken during the manufacturing process to ensure the paint systems meets the higher standards, the paint is subject to normal operational wear and tear due to the mooring ropes. To maximize life expectancy, inspection is required every three months and inspection should take place when they are subjected to abnormal actions such as being knocked by equipment or when used for other applications.

TECHNICAL SUPPORT

Technical advice, design and enquiries should be directed to your local Trelleborg Marine and Infrastructure office.

Refer to Trelleborg Bollard Operations, Installation and Maintenance (OIM) Manual for more information.



APPENDIX - IMPERIAL UNITS

Tee Bollard

FEATURES

- General purpose applications up to 300 tons
- Suitable for rope angles from -15° to +75°

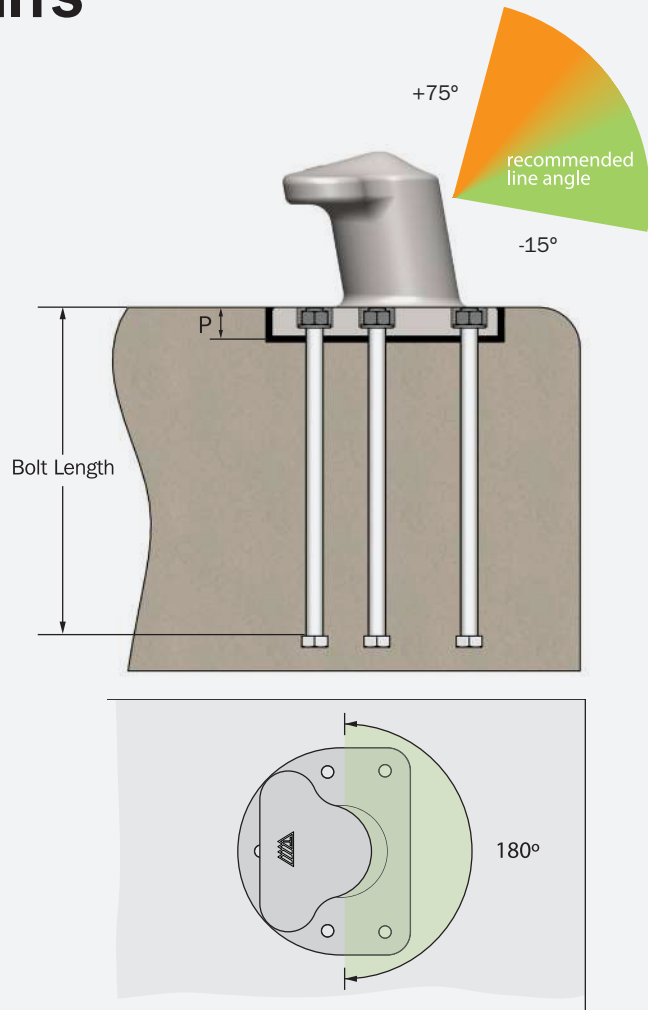

↑ seaward side

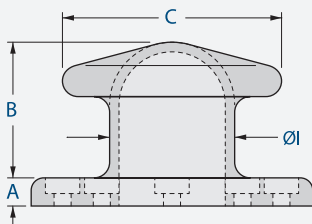
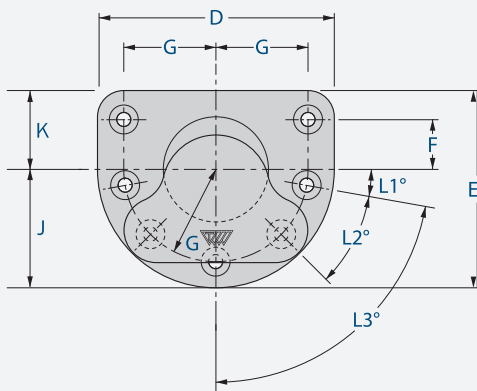

DIMENSION	BOLLARD CAPACITY (Tonnes)									
	15	30	50	80	100	125	150	200	250	300
A	1-3/8"	1-1/2"	1-7/8"	1-15/16"	2-3/8"	2-9/16"	2-3/4"	3-1/8"	3-15/16"	3-15/16"
B	9-1/4"	10-1/16"	13-3/4"	14-15/16"	16-1/8"	16-1/8"	17-1/8"	19-11/16"	24"	26-3/8"
C	13"	13-3/4"	18-1/2"	21-1/4"	20-11/16"	23-5/8"	25-3/16"	29-1/8"	35-1/16"	38-9/16"
D	16-1/8"	17-11/16"	25-3/16"	25-3/16"	31-1/8"	33-7/16"	35-7/16"	39-3/8"	42-15/16"	47-1/4"
E	13-3/16"	14-3/4"	21-1/4"	21-5/8"	25-3/16"	27-9/16"	29-1/2"	33-7/16"	36"	36-7/16"
F	3-1/8"	3-15/16"	5-7/8"	6-5/16"	6-7/8"	6-7/8"	7-7/8"	8-7/8"	9-13/16"	7-7/8"
G	6-1/8"	6-7/8"	9-13/16"	9-13/16"	12-13/16"	12-13/16"	13-3/4"	14-3/4"	16-3/4"	18-11/16"
ØI	5-7/8"	7-7/8"	10-1/4"	10-1/4"	11-13/16"	12-3/16"	12-13/16"	14-3/4"	16-15/16"	19-11/16"
J	8-1/16"	8-7/8"	12-5/8"	12-5/8"	15-9/16"	16-3/4"	17-11/16"	19-11/16"	21-7/16"	23-5/8"
K	5-1/8"	5-7/8"	8-11/16"	9-1/16"	9-5/8"	10-13/16"	11-13/16"	13-3/4"	14-9/16"	12-13/16"
L1°	30°	30°	30°	15°	10°	10°	10°	0°	5°	23°
L2°	-	-	-	45°	40°	40°	40°	36°	34°	26°
L3°	60°	60°	60°	-	80°	80°	80°	72°	68°	52°
Bolts	1"	1-1/8"	1-3/8"	1-5/8"	1-5/8"	1-7/8"	1-7/8"	2-1/4"	2-1/2"	2-1/2"
Bolt Length	19-11/16"	19-11/16"	19-11/16"	31-1/2"	31-1/2"	35-7/16"	39-3/8"	39-3/8"	54-1/8"	61"
P	1-15/16"	2-1/16"	2-1/2"	2-9/16"	2-15/16"	3-1/8"	3-3/8"	3-3/4"	4-1/2"	4-1/2"
Quantity	5	5	5	6	7	7	7	8	8	10

P = bollard base recess mounting depth
= hold-down bolt protrusion height

[units: inches]

Horn Bollard

FEATURES

- General purpose applications up to 250 tons
- Suitable for rope angles from -15° to +75°
- Two lines may share a single bollard (subject to bollard capacity)

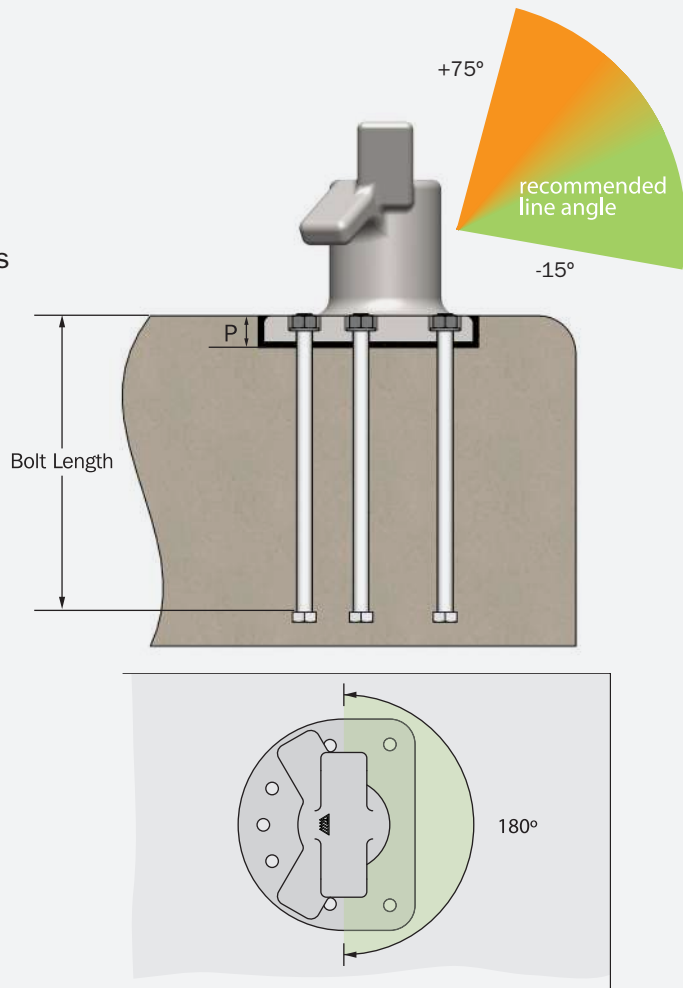

↑ seaward side

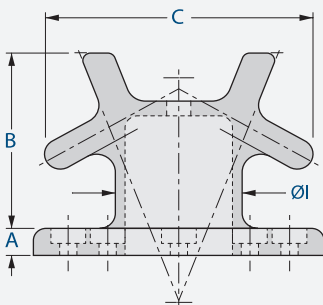
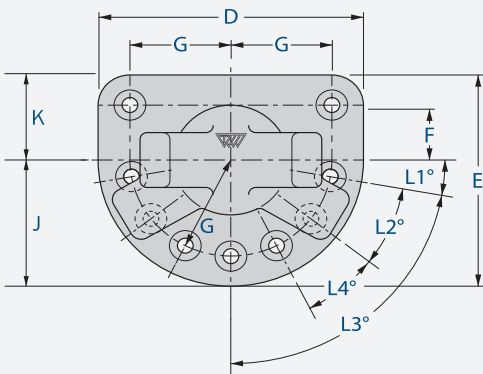

DIMENSION	BOLLARD CAPACITY (Tonnes)									
	15	30	50	80	100	125	150	200	250	300
A	1-3/8"	1-3/8"	1-15/16"	1-15/16"	2-9/16"	2-3/4"	2-3/4"	3-1/8"	3-9/16"	3-15/16"
B	14-9/16"	16-1/8"	19-11/16"	20-1/2"	22-7/16"	23-7/16"	23-7/16"	26"	27-3/16"	33-7/16"
C	16-1/8"	17-11/16"	23-5/8"	23-5/8"	26-3/8"	27-9/16"	30-5/16"	32-5/16"	33-11/16"	38-3/8"
D	16-1/8"	18-7/8"	25-3/16"	25-9/16"	31-1/2"	32-5/16"	36-1/4"	39-3/8"	39-3/8"	47-1/4"
E	13-3/16"	15-15/16"	21-1/4"	22-1/16"	25-9/16"	26-3/8"	30-5/16"	33-7/16"	33-7/16"	36-7/16"
F	3-1/8"	3-15/16"	5-7/8"	6-5/16"	6-7/8"	6-7/8"	7-7/8"	8-7/8"	8-7/8"	7-7/8"
G	6-1/8"	6-7/8"	9-13/16"	9-13/16"	12-13/16"	12-13/16"	13-3/4"	14-3/4"	14-3/4"	18-11/16"
ØI	6-5/16"	7-7/8"	10-1/4"	10-1/4"	10-13/16"	11-13/16"	12-13/16"	13-3/4"	14-3/4"	17-11/16"
J	8-1/16"	9-7/16"	12-5/8"	12-13/16"	15-3/4"	16-1/8"	18-1/8"	19-11/16"	19-11/16"	23-5/8"
K	5-1/8"	6-1/2"	8-11/16"	9-1/4"	9-13/16"	10-1/4"	12-3/16"	13-3/4"	13-3/4"	12-13/16"
L1°	30°	30°	30°	15°	10°	12°	10°	0°	0°	23°
L2°	60°	60°	60°	45°	40°	39°	40°	36°	36°	26°
L3°	-	-	-	-	80°	78°	80°	72°	72°	52°
L4°	-	-	-	-	40°	39°	40°	36°	36°	26°
Bolts	1"	1-1/8"	1-3/8"	1-5/8"	1-5/8"	1-7/8"	1-7/8"	2-1/4"	2-1/2"	2-1/2"
Bolt Length	19-11/16"	19-11/16"	19-11/16"	31-1/2"	31-1/2"	35-7/16"	39-3/8"	39-3/8"	54-1/8"	61"
P	1-15/16"	1-15/16"	2-9/16"	2-9/16"	3-1/8"	3-3/8"	3-3/8"	3-3/4"	4-1/8"	4-1/2"
Quantity	5	5	5	6	7	7	7	8	8	10

P = bollard base recess mounting depth
= hold-down bolt protrusion height

[units: inches]

Kidney Bollard

FEATURES

- General purpose applications up to 200 tons
- Suitable for rope angles from -15° to $+60^{\circ}$
- Suitable for warping operations

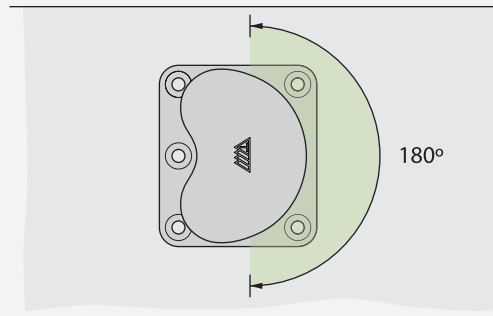
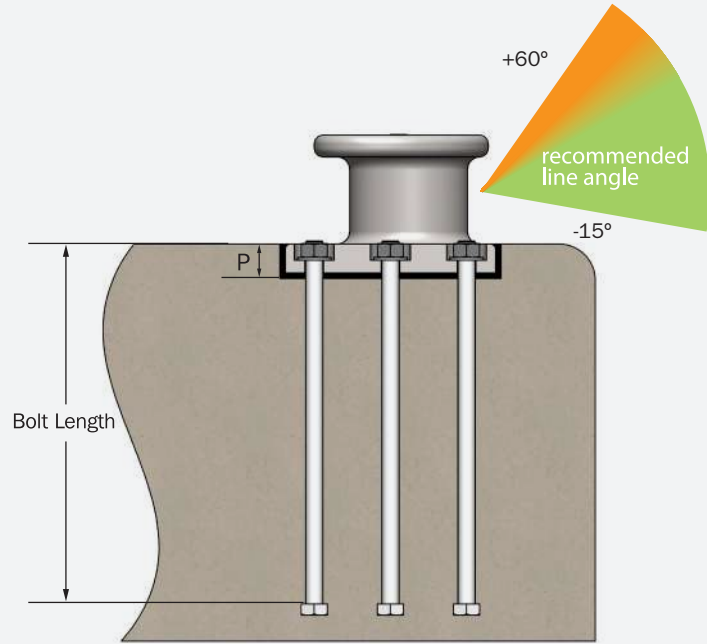

↑ seaward side

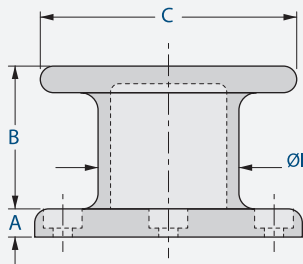
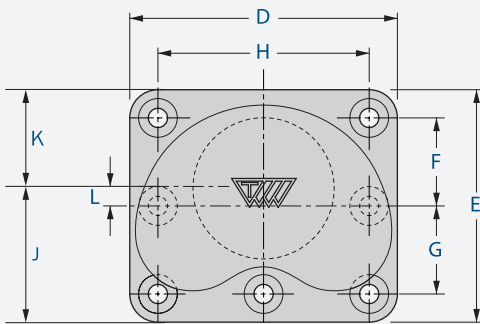

DIMENSION	BOLLARD CAPACITY (Tonnes)							
	15	30	50	80	100	125	150	200
A	1-3/16"	1-3/8"	1-3/4"	2-9/16"	2-9/16"	2-3/4"	3-1/8"	3-1/4"
B	8-1/4"	9-1/16"	10-5/8"	11-1/4"	12-3/16"	13-1/8"	14-15/16"	15-9/16"
C	11-13/16"	13-9/16"	17-11/16"	18-1/2"	19-11/16"	21-5/8"	24-13/16"	27-9/16"
D	12-5/8"	14-3/16"	21-1/4"	22-1/16"	23-1/4"	26-3/4"	29-15/16"	39-3/8"
E	12-5/8"	14-3/16"	21-1/4"	18-1/8"	19-5/16"	22-13/16"	26"	33-7/16"
F	-	-	-	-	6-7/8"	8-1/4"	9-13/16"	11-13/16"
G	-	-	-	-	6-7/8"	8-1/4"	9-13/16"	11-13/16"
F+G	8-11/16"	10-1/4"	15-3/4"	12-5/8"	13-3/4"	16-9/16"	19-11/16"	23-5/8"
H	8-11/16"	10-1/4"	15-3/4"	16-9/16"	17-11/16"	20-1/2"	23-5/8"	29-1/2"
ØI	6-5/16"	7-7/8"	10-1/4"	10-1/4"	10-5/8"	11-13/16"	13-3/4"	14-15/16"
J	6-5/16"	7-1/16"	10-5/8"	11"	12-3/8"	14-3/16"	16-5/16"	21-1/16"
K	6-5/16"	7-1/16"	10-5/8"	7-1/16"	6-7/8"	8-11/16"	9-5/8"	12-3/8"
L	-	-	-	-	2-3/4"	2-3/4"	3-3/8"	4-5/16"
Bolts	1"	1-1/8"	1-3/8"	1-5/8"	1-5/8"	1-7/8"	1-7/8"	2-1/4"
Bolt Length	19-11/16"	19-11/16"	19-11/16"	31-1/2"	31-1/2"	39-3/8"	39-3/8"	39-3/8"
P	1-3/4"	1-15/16"	2-3/8"	3-1/8"	3-1/8"	3-3/8"	3-3/4"	3-13/16"
Quantity	4	4	4	5	7	7	7	7

P = bollard base recess mounting depth
= hold-down bolt protrusion height

[units: inches]

Cleat Bollard

FEATURES

- General purpose applications up to 35 tons
- Suitable for rope angles from -15° to +60°
- Suitable for small wharves or jetties and marinas
- Two lines may share a single bollard (subject to bollard capacity)

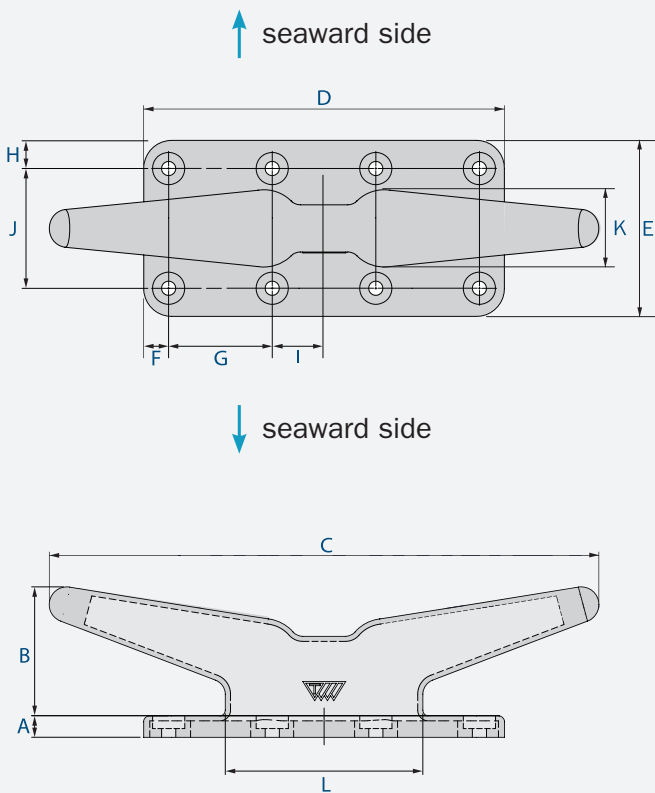
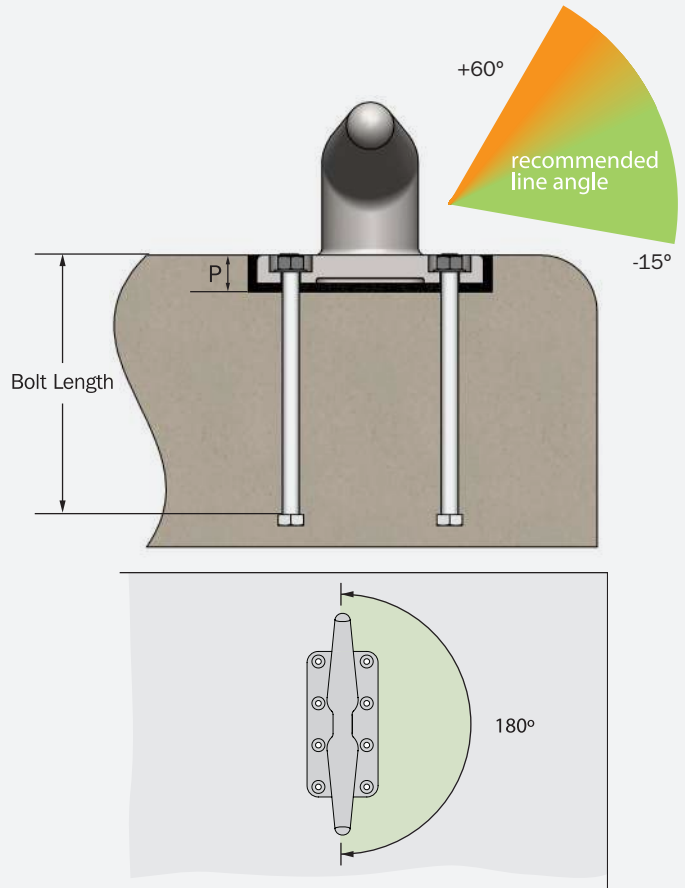
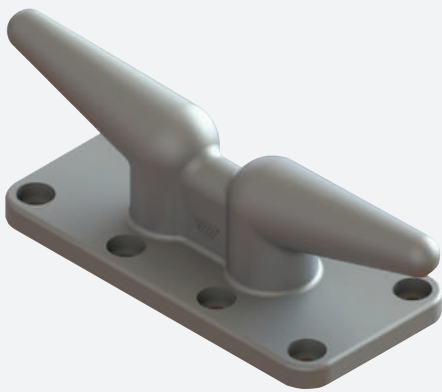

DIMENSION	BOLLARD CAPACITY (Tonnes)				
	15	20	25	30	35
A	1"	1-3/16"	1-1/2"	1-9/16"	1-3/4"
B	6-5/8"	7-5/16"	8-7/16"	10"	10-11/16"
C	20-1/16"	26-3/16"	31-7/8"	37-13/16"	44-1/8"
D	16-1/8"	20-1/16"	24"	26"	33-1/16"
E	8-11/16"	11"	12-3/16"	12-3/16"	15-3/4"
F	1-9/16"	1-15/16"	1-15/16"	1-3/4"	2-3/8"
G	6-1/2"	8-1/16"	10-1/16"	7-1/2"	9-7/16"
H	1-9/16"	1-15/16"	1-15/16"	1-3/4"	2-3/8"
I	0"	0"	0"	3-3/4"	4-3/4"
J	5-1/2"	7-1/16"	8-1/4"	8-11/16"	11"
K	3-9/16"	4-5/16"	5-1/8"	5-7/8"	6-11/16"
L	9-1/4"	11"	12-13/16"	14-9/16"	16-15/16"
Bolt	3/4"	1"	1"	1"	1-1/8"
Bolt Length	13-3/4"	18-1/8"	18-1/8"	18-1/8"	18-1/8"
P	1-9/16"	1-3/4"	2-1/16"	2-3/16"	2-3/8"
Quantity	6	6	6	8	8

P = bollard base recess mounting depth
 = hold-down bolt protrusion height [units: inches]

Double Bitt Bollard

FEATURES

- General purpose applications up to 200 tons
- Suitable for mooring multiple lines (subject to bollard capacity)
- Concrete filled (optional)
- Suitable for rope angles from -15° to +60°

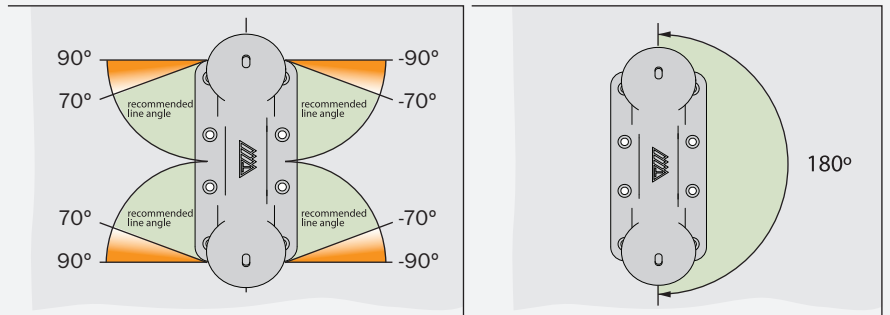
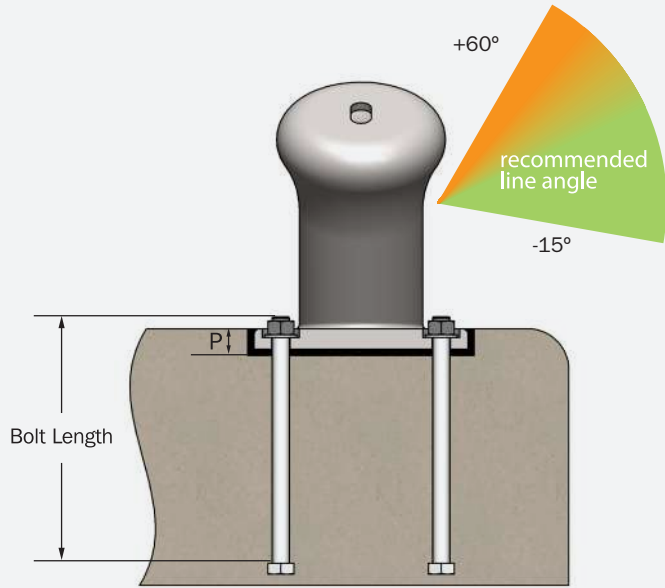

Allowable mooring line angle shown is applicable when mooring line is secured on one bitt of the bollards

↑ seaward side

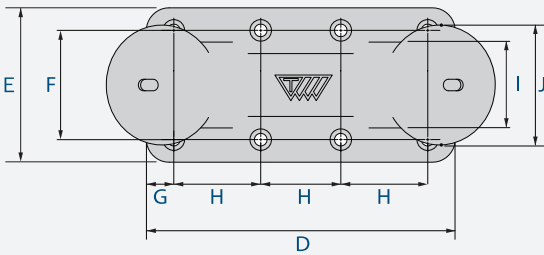

↓ seaward side

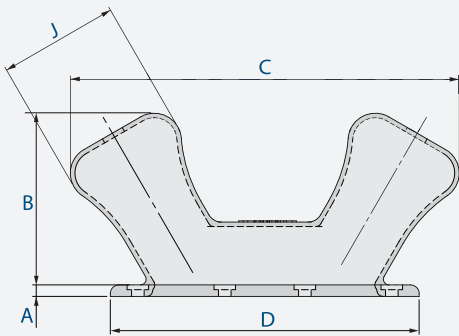

DIMENSION	BOLLARD CAPACITY (Tonnes)							
	20	30	50	75	100	125	150	200
A	5/8"	7/8"	1"	1-3/8"	1-3/4"	1-7/8"	1-7/8"	2-3/16"
B	11-7/16"	13-3/4"	16-1/8"	20-1/16"	23-5/8"	27-9/16"	29-1/2"	33-1/16"
C	25-9/16"	30-1/4"	35-3/4"	44-1/2"	51-3/8"	59-7/16"	64-15/16"	72-1/16"
D	21-1/4"	24"	28-3/8"	34-1/4"	40-3/16"	46-1/16"	50"	56-5/16"
E	11"	12-3/16"	14-3/16"	17-5/16"	20-1/2"	23-1/4"	25-3/16"	28-3/8"
F	7-1/2"	8-11/16"	10-5/8"	13"	15-3/8"	17-5/16"	19-5/16"	20-7/8"
G	1-3/4"	1-3/4"	1-3/4"	2-3/16"	2-9/16"	2-15/16"	2-15/16"	3-3/4"
H	5-7/8"	7-1/16"	8-1/4"	7-1/2"	8-3/4"	10-1/16"	11"	12-3/16"
I	5-1/8"	6-5/16"	7-1/2"	9-1/16"	10-5/8"	12-3/16"	13-3/8"	14-3/16"
J	6-13/16"	9-1/16"	10-1/4"	13"	14-9/16"	16-15/16"	18-7/8"	20-1/2"
Bolt	3/4"	1"	1-1/8"	1-3/8"	1-5/8"	1-5/8"	1-7/8"	2-1/4"
Bolt Length	11-13/16"	11-13/16"	17-11/16"	19-11/16"	23-5/8"	29-1/2"	33-7/16"	42-1/8"
P	1-1/4"	1-7/16"	1-9/16"	1-15/16"	2-3/8"	2-1/2"	2-1/2"	2-3/4"
Quantity	8	8	8	10	10	10	10	10

P = bollard base recess mounting depth
= hold-down bolt protrusion height

[units: inches]

Single Bitt Bollard

FEATURES

- General purpose applications up to 200 tons
- Suitable for rope angles from -15° to $+75^\circ$
- Two lines may share a single bollard (subject to bollard capacity)
- Concrete filled (optional)

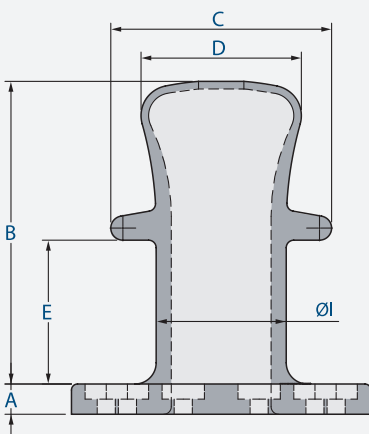
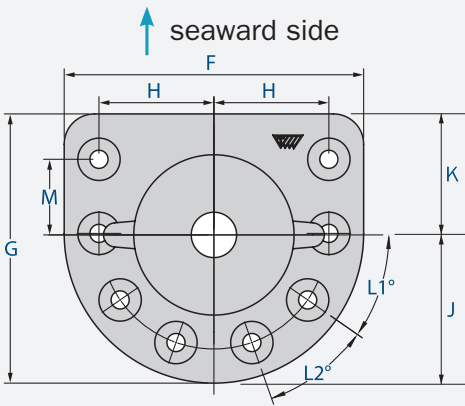
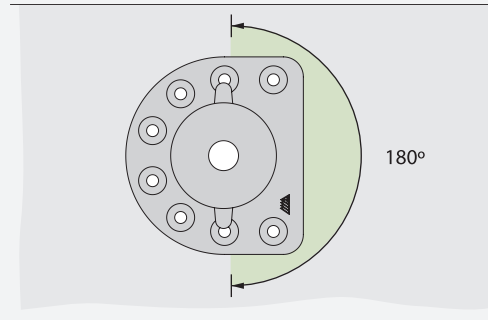
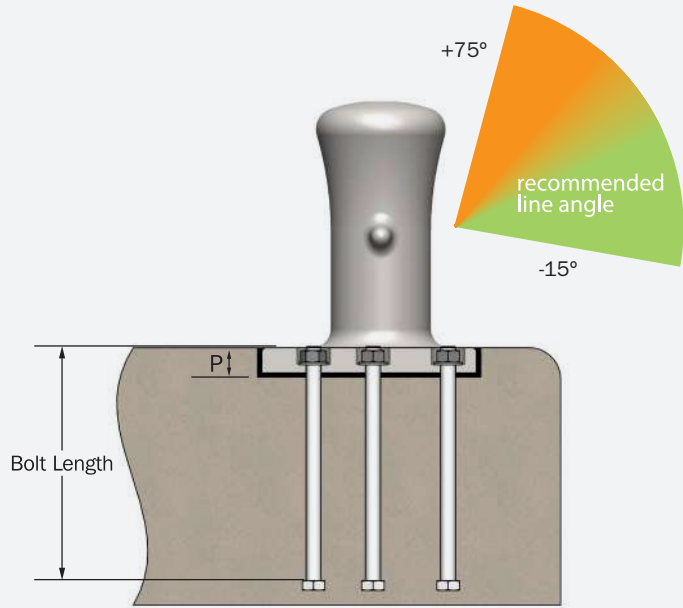

DIMENSION	BOLLARD CAPACITY (Tonnes)							
	15	30	50	75	100	125	150	200
A	1-3/16"	1-3/4"	2-3/16"	2-3/8"	2-9/16"	2-15/16"	3-1/8"	3-9/16"
B	14-11/16"	19-1/2"	25-3/8"	29-1/4"	31-1/4"	33-7/16"	35-9/16"	39-9/16"
C	10-1/4"	12-13/16"	17-11/16"	18-1/8"	20-1/16"	23-5/8"	24-7/16"	27-15/16"
D	8-1/4"	9-5/8"	13-3/8"	13-3/4"	14-3/4"	16-1/8"	16-9/16"	19-5/16"
E	5-11/16"	6-5/16"	10-1/4"	11-5/16"	12-13/16"	14-3/8"	14-15/16"	18-5/16"
F	14-3/16"	16-9/16"	20-7/8"	25-9/16"	29-15/16"	32-1/2"	35-7/16"	39"
G	12-3/8"	14-15/16"	18-7/8"	22-13/16"	26-15/16"	29-1/8"	31-7/8"	35-1/16"
H	5-1/8"	6-5/16"	8-1/16"	9-13/16"	11-7/16"	12-5/16"	13-9/16"	14-15/16"
ØI	5-7/8"	7-5/16"	9-7/16"	9-13/16"	11"	12-3/16"	13"	15-3/8"
J	7-1/16"	8-1/4"	10-7/16"	12-13/16"	14-15/16"	16-1/8"	17-11/16"	19-1/2"
K	5-5/16"	6-11/16"	8-7/16"	10-1/16"	12"	13"	14-3/16"	15-9/16"
M	2-15/16"	4-3/4"	6-1/8"	7-1/16"	8-7/16"	9-1/16"	10-1/16"	11"
L1°	50°	24°	13°	13°	5°	4°	5°	35°
L2°	-	66°	50°	49°	43°	44°	44°	35°
Bolt	1"	1-1/8"	1-3/8"	1-5/8"	1-7/8"	1-7/8"	2-1/4"	2-1/4"
Bolt Length	15-3/4"	19-11/16"	23-5/8"	23-5/8"	29-1/2"	35-7/16"	39-3/8"	39-3/8"
P	1-3/4"	2-3/8"	2-3/4"	2-15/16"	3-1/8"	3-9/16"	3-3/4"	4-1/8"
Quantity	4	5	6	6	7	7	7	8

[units: inches]

P = bollard base recess mounting depth
= hold-down bolt protrusion height

Pillar Bollard

FEATURES

- General purpose applications up to 200 tons
- Suitable for rope angles from -15° to $+60^\circ$
- Suitable for warping operations
- 360 degree horizontal line angle use
- Can be utilized from all sides of jetty

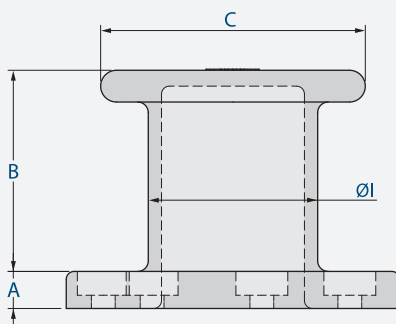
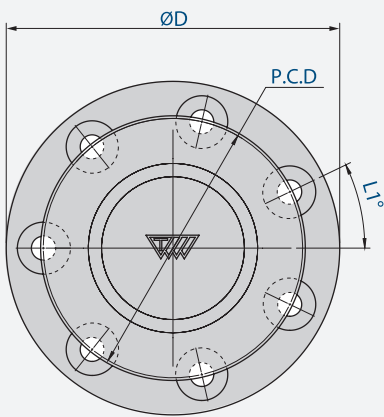
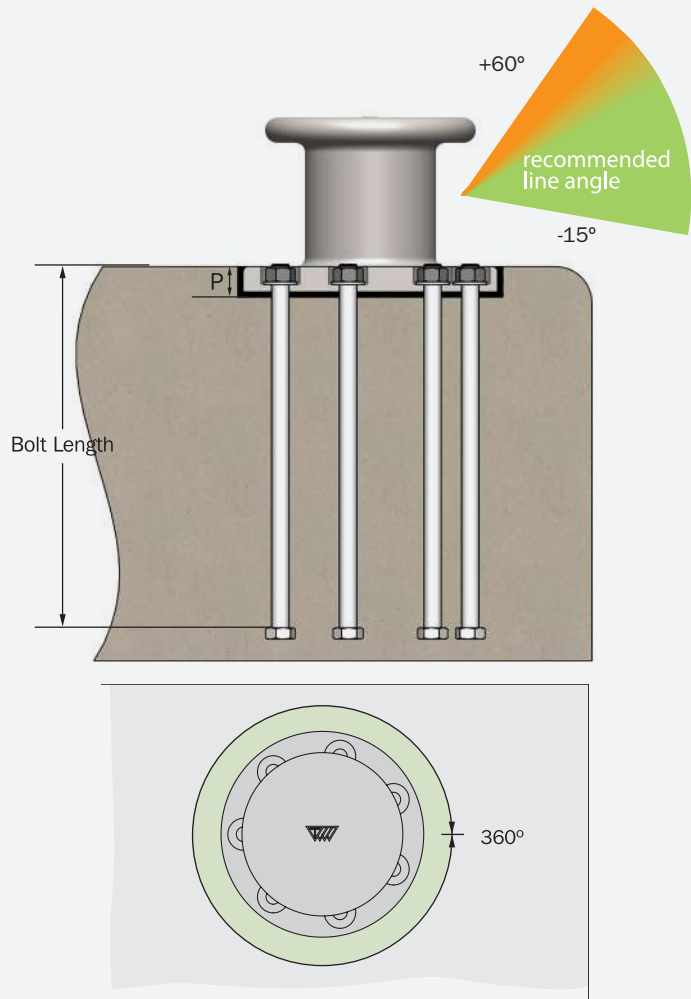

DIMENSION	BOLLARD CAPACITY (Tonnes)							
	10	15	30	50	75	100	150	200
A	13/16"	1"	1-3/8"	1-9/16"	1-3/4"	1-15/16"	2-3/16"	2-9/16"
B	6-1/8"	9-7/16"	10-1/16"	11-5/8"	14-3/8"	15-9/16"	16-15/16"	17-11/16"
C	7-7/8"	11-7/16"	15-3/8"	16-15/16"	17-5/16"	20-1/2"	24-13/16"	27-3/16"
ØD	10-5/8"	16-9/16"	19-11/16"	22-13/16"	24-13/16"	27-9/16"	31-1/2"	35-7/16"
P.C.D	7-1/2"	11-13/16"	14-3/8"	17-11/16"	19-5/16"	21-5/8"	23-5/8"	27-9/16"
ØI	4-15/16"	7-1/16"	9-7/16"	10-5/8"	10-5/8"	11-13/16"	13-3/4"	15-3/4"
L1°	-	-	-	26°	26°	26°	-	-
Bolt	3/4"	1"	1-3/8"	1-3/8"	1-5/8"	1-7/8"	2-1/4"	2-1/2"
Bolt Length	13-3/4"	15-3/4"	21-5/8"	31-1/2"	39-3/8"	39-3/8"	39-3/8"	39-3/8"
P	1-3/8"	1-9/16"	1-15/16"	2-3/16"	2-3/8"	2-9/16"	2-3/4"	3-1/8"
Quantity	4	4	4	7	7	7	8	8

P = bollard base recess mounting depth
 = hold-down bolt protrusion height

[units: inches]



DISCLAIMER

Trelleborg AB has made every effort to ensure that the technical specifications and product descriptions in this brochure are correct.

The responsibility or liability for errors and omissions cannot be accepted for any reason whatsoever. Customers are advised to request a detailed specification and certified drawing prior to construction and manufacture. In the interests of improving the quality and performance of our products and systems, we reserve the right to make specification changes without prior notice. All dimensions, material properties and performance values quoted are subject to normal production and testing tolerances.

This brochure supersedes the information provided in all previous editions. If in doubt, please check with Trelleborg Marine and Infrastructure.

**© Trelleborg AB, PO Box 153, 231 22
Trelleborg, Sweden.**

This brochure is the copyright of Trelleborg AB and may not be reproduced, copied or distributed to third parties without the prior consent of Trelleborg AB in each case.





**For a smarter approach
to your next project,
get in touch today.**

Email: marine_infra@trelleborg.com





Trelleborg is a world leader in engineered polymer solutions that seal, damp and protect critical applications in demanding environments. Its innovative solutions accelerate performance for customers in a sustainable way.

WWW.TRELLEBORG.COM/MARINEANDINFRASTRUCTURE



LinkedIn: [Linkedin.com/company/trelleborg-marine-and-infrastructure](https://www.linkedin.com/company/trelleborg-marine-and-infrastructure)

YouTube: [Youtube.com/c/TrelleborgMarineInfrastructure](https://www.youtube.com/c/TrelleborgMarineInfrastructure)

Facebook: [TrelleborgMarineandInfrastructure](https://www.facebook.com/TrelleborgMarineandInfrastructure)

Twitter: [@TrelleborgMI](https://twitter.com/TrelleborgMI)