

NPC Core Drill Quick Change Adapter

Data Sheet

Advantages of the Quick-Change Adapters

- Greatly reduces core drill change time
- Double-shoulder design prevents runout
- Single locking pin for fast disengagement
- Designed to fit all NPC Hydrokor coring machines
- Hard nickel plating for corrosion resistance and durability

Quick Change Adapter Installation:

1. Mount male adaptor on spindle using (4) grade 5 bolts or higher.
2. Mount female adaptors to frequently used bits.

Changing Core Drills:

Removal -

1. Depress release button on the pin and slide out.
2. Slide core drill forward off the shaft.

Installation -

1. Lift core drill so female adaptor lines up with the male adaptor. Slide forward mating the adaptors.
2. Rotate the core drill so the pin hole lines up with the tether bolt.
3. Push the release button on the locking pin and insert the pin in the hole.
4. Check to be sure the pin is fully seated and locked in position.

Replacement Locking Pins -
Grainger P/N 1E846

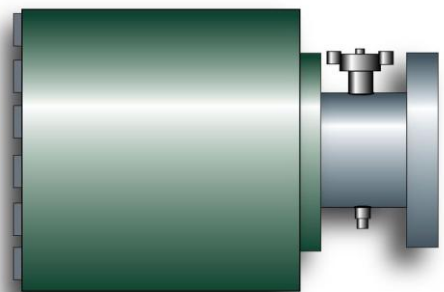
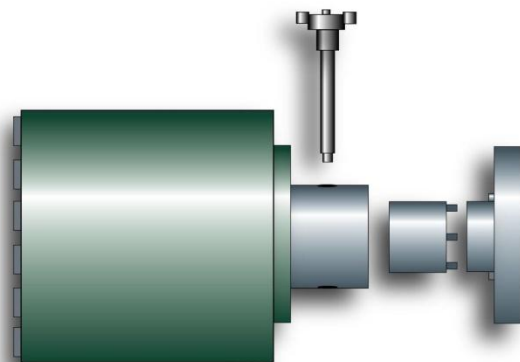

CAUTION:

1. Coat Quick-Change Core Drill with Form Release or equivalent to lubricate and prevent buildup of slurry.
 2. Never run Quick-Change without the pin. This will damage the adaptor.
 3. On all Core Drills and Adaptors, use only Grade 5 or higher bolts.
 4. Never clean Adaptors with hard abrasives. Use brass cleaner, etc. to protect plating.
-