

● Control Links



Features

A range of Control Links incorporating Spherilastik™ Bearings are available and typical sizes are listed below. Further details are available on request.

- Typical applications on off-highway vehicle suspensions, traction and braking reaction rods and panhard rods.
- High load capacity with integral maintenance free Spherilastik™ flexible bush.
- Option for either a through hole or pin type end connection.

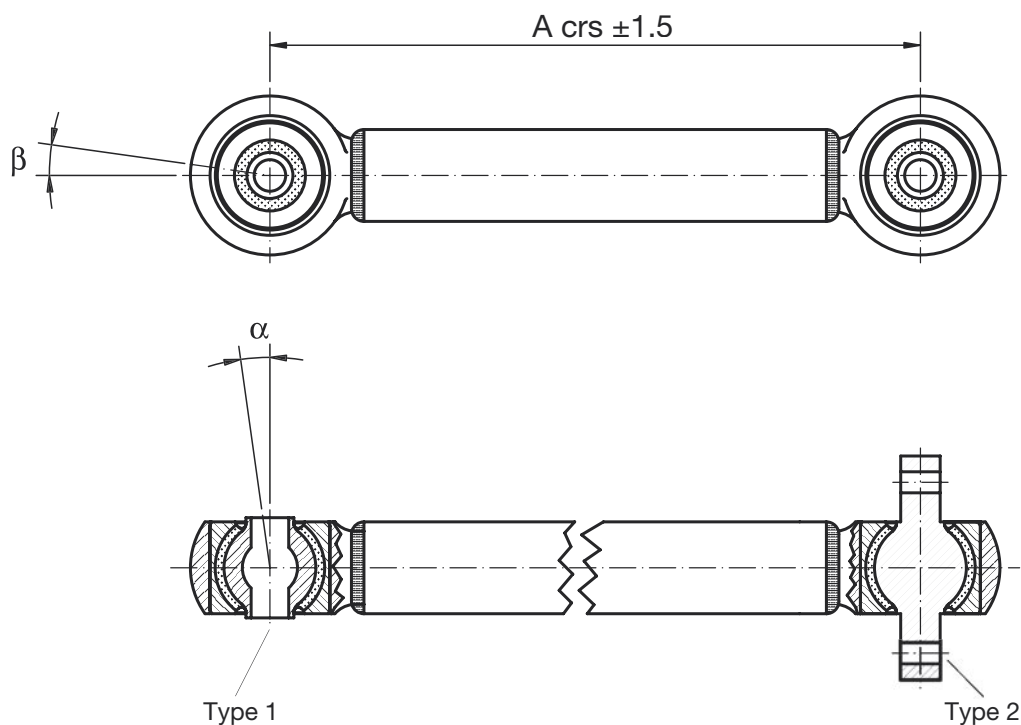

General guidance notes for selection:

1. Properties quoted for the components in this leaflet relate to continuous steady loading or deformation conditions.
2. For continuous dynamic cyclic loading or deformation, the maximum values should be reduced to approximately 30% of the figures quoted, depending on frequency.
3. For medium and low incidence loading and deformation, the tabled values may be increased up to 2 to 3 times.
4. Combined stressing in the different modes and the effects of stress reversals may require a more critical assessment.

Part no.	Spherilastik Part no.	Type	A Distance	Max. Load kN	+/- beta degrees	+/- alpha degrees	Weight (kg)
10-03292-01	10-00237-01	1	720,0	58,0	6	8	16,0
10-03283-01	10-00878-01	2	490,0	58,0	6	8	12,0
10-03280-01	10-02512-01	2	530,0	80	7	8,0	28,0