

# Compactor Shearmount



## Features

- High tensile strength superior grade rubber compounds bonded to steel mounting plates.
- Compact and easy to install, maintenance free.
- Can be used in pairs in an angled arrangement, loaded in combined compression and shear to optimize vibration isolation performance.

Trellex extreme™ Compactor Shearmountings support high compressive loads with low shear stiffness.

They are suitable for suspension of vibratory compactor drums on compactor roller vehicles and vibratory screen equipment.

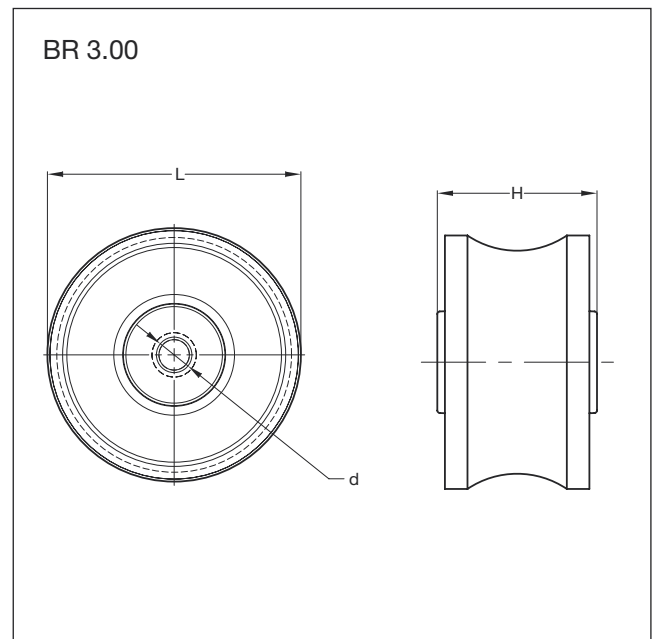
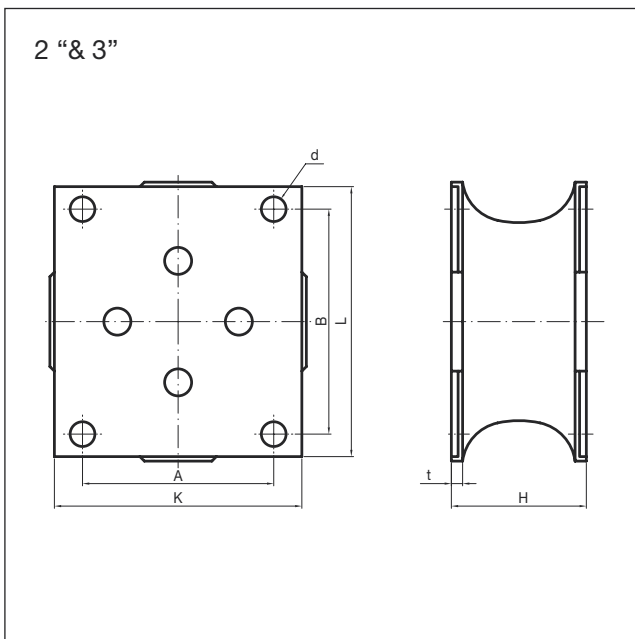

## 2 & 3" shear / compression Mountings

Type	Part no.	Dimension							Compression		Shear		weight kg
		A	B	K	L	H	d	t	Max load (kg)	deflection (mm)	Max load (kg)	deflection (mm)	
2" -55	10-01798-01	100	85	120	110	60	11	5	670	9	70	7,5	1,1
2" -60	10-01618-01	100	85	120	110	60	11	5	840	9	90	7,5	1,1
2" -65	10-01619-01	100	85	120	110	60	11	5	1010	9	100	7,5	1,1
3" -55	10-00067-01	146	146	182	182	76	13	7,5	2000	11	220	13	3,4
3" -60	10-00065-01	146	146	182	182	76	13	7,5	2500	11	280	13	3,4
3" -65	10-00066-01	146	146	182	182	76	13	7,5	3000	11	340	13	3,4
BR 3.00-45	20-01038-01				100	63	M12		180	3,0	85	9,0	0,35
BR 3.00-55	20-01039-01				100	63	M12		275	3,0	125	9,0	0,35
BR 3.00-60	20-01040-01				100	63	M12		340	3,0	155	9,0	0,35