

# Cab Mounting

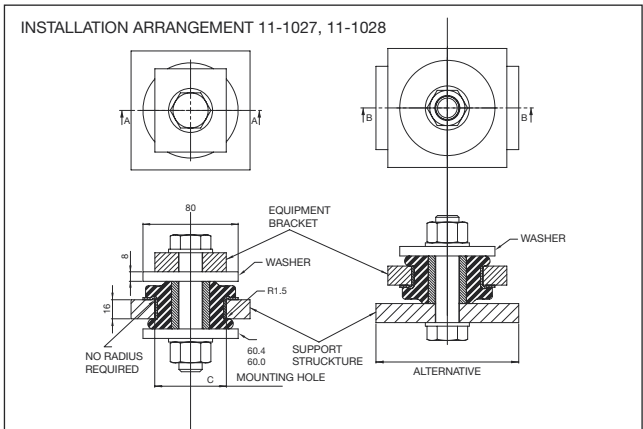

Specially profiled rubber sections together with bump and rebound washers provide optimum cab suspension and vibration isolation characteristics.

Typical applications on off-highway vehicles are cabs but also on engine transmissions.

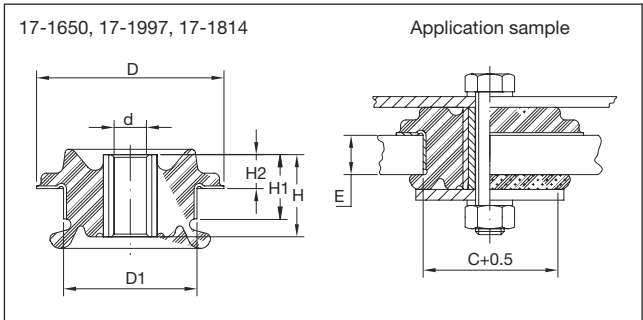
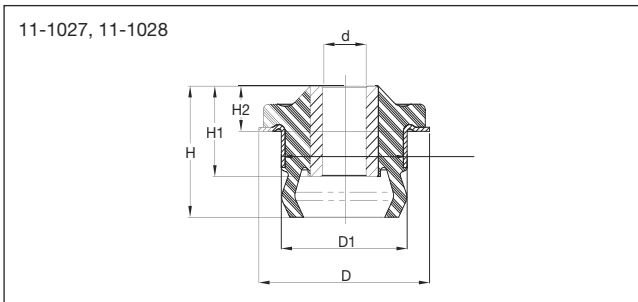
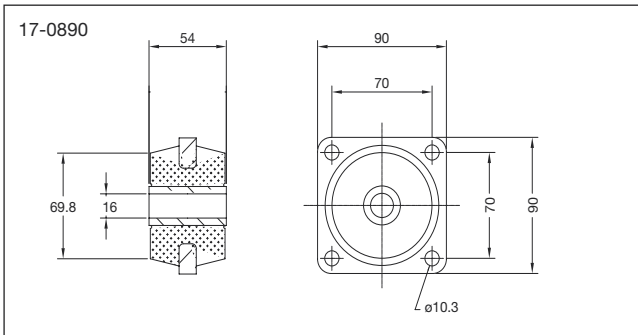
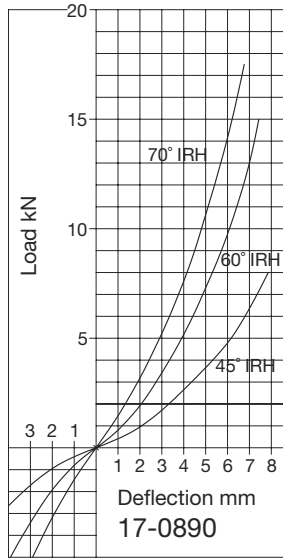

Type	Part no.	Dimension								Bolt Size	Max. Bolt Torque Nm	Max. Load kg	Top & Bottom Washer Part no.
		D	D1	d	H	H1	H2	E	C				
11-1027-45	20-01107-01	80	59	20,3	58	40	20	16	60	M20	380	75	20-00003-01
11-1027-60	20-01108-01	80	59	20,3	58	40	20	16	60	M20	380	150	20-00003-01
11-1028-45	20-00875-01	80	59	16,3	58	40	20	16	60	M16	250	75	20-00532-01
11-1028-60	20-01109-01	80	59	16,3	58	40	20	16	60	M16	250	150	20-00532-01
17-1650-45	10-00552-01	105	75	22	55	46	19	20	75	M20	180	190	20-00533-01
17-1650-60	10-00944-01	105	75	22	55	46	19	20	75	M20	180	350	20-00533-01
17-1997-45	10-00626-01	105	75	16,5	55	46	19	20	75	M16	180	190	20-01494-01
17-1997-60	10-00627-01	105	75	16,5	55	46	19	20	75	M16	180	350	20-01494-01
17-1814-45	10-00598-01	120	89	25	62	47	13	25	89	M24	270	350	20-00534-01
17-1814-60	10-00603-01	120	89	25	62	47	13	25	89	M24	270	800	20-00534-01
17-0890-45	10-00440-01	See Drawing								M16	250	300	20-00532-01
17-0890-60	10-00441-01	See Drawing								M16	250	500	20-00532-01
17-0890-70	10-00442-01	See Drawing								M16	250	750	20-00532-01