

Metalastik® type Cushyfloat



Features

Originally designed for use with marine engines, this compact low profile mounting is easy to install. It combines 3 way control of the suspended equipment with relatively large static deflections where the rubber is loaded in shear and compression.

The design incorporates bump and rebound control features which limit excessive movements under shock loading. Top metal cover gives protection against oil contamination and protective finish resists corrosion attack. Propeller thrust on marine applications is accommodated. There are four sizes in the standard range with varying degrees of rubber hardness cater for point loads from 32 kg to 3000 kg. Natural frequencies as low as 8 Hz are possible.

Note: When used in marine engine applications with thrust forces involved, the maximum load capacity is substantially reduced, see table below!

Metalastik® type Cushyfloat™

The Cushyfloat™ mounting is a general purpose unit designed to provide effective isolation of vibration and noise arising from both static and mobile equipment including:

- Marine, industrial and vehicle engines
- Generator sets
- Pumps
- Compressors

The load ratings specified are associated with the supported mass only and do not include standard (LRS/DVN) seaway motions or torque reaction.

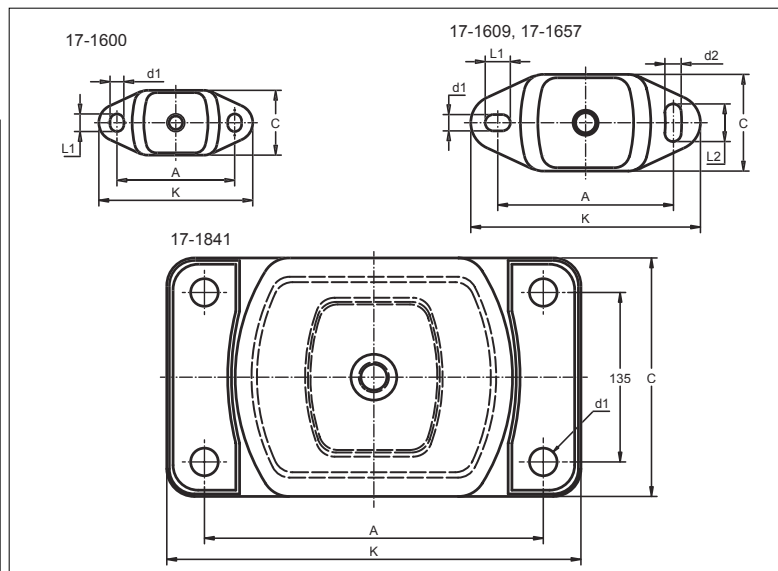
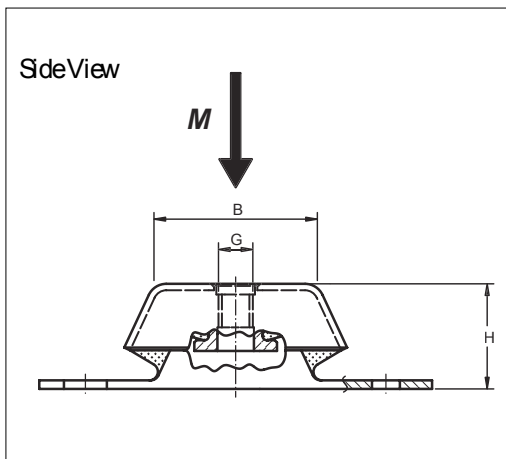

Product No.	Dimensions in mm										Weight (kg)	M-max (kg)	M-max* (kg)		
	B	C	A	K	H	d1	L1	d2	L2	G					
17-1600-45														50	35
17-1600-55	62	60	100	120	38	11	14				M12	0.3	65	55	
17-1600-65														100	80
17-1609-45														150	95
17-1609-55														210	140
17-1609-65	76	75	140	183	50	13	20	13	30	M16	0.9	300	210		
17-1609-75														450	315
17-1657-45														350	250
17-1657-55														520	370
17-1657-65	87	112	182	230	70	18	26	18	34	M20	2.4	800	560		
17-1841-40														950	630
17-1841-50														1400	945
17-1841-60	145	190	270	330	112	22				M24	9.6	2200	1575		
17-1841-70														3000	2100

Trelleborg Industrial AVS operates a policy of continuous improvement and development. We reserve the right to change design and specification of our products without prior notification or alteration of literature. We will not be held responsible for any danger or damage incurred through improper use or installation.

*Marine engine applications with thrust forces M-max (kg)