



Instructions for use: Packers

TABLE OF CONTENTS

1.0. IDENTIFICATION	4
1.1. TYPE OF PRODUCT	4
1.2. MANUFACTURER	4
2.0. PRODUCT DESCRIPTION	5
2.1. BASIC FUNCTIONS AND AREAS OF APPLICATION	5
2.2. BASIC DATA	5
2.3. ENVIRONMENTAL CONDITIONS AND RESTRICTIONS OF USE	5
2.4. SAFETY AND PERSONAL PROTECTIVE EQUIPMENT	5
3.0. DEFINITIONS	6
4.0. PREPARATION OF PRODUCT FOR USE	6
4.1. TRANSPORT	6
4.2. SAFETY PRECAUTIONS BEFORE USE	6
4.3. REMOVAL OF PACKAGING	7
4.4. DISPOSAL OF PACKAGING	7
4.5. STORAGE AND PROTECTION OF PRODUCTS	7
4.6. STORAGE OF INSTRUCTIONS AND PERIODIC TEST REPORTS	7
5.0. INSTRUCTIONS FOR SAFE USE	8
5.1. RECOMMENDATIONS FOR SAFE AND EFFICIENT WORK	8
5.1.1. HANDLING SAVA PACKERS	8
5.1.2. WORKING ENVIRONMENT	9
5.2. CHOOSING A SUITABLE SAVA PACKER	9
5.2.1. CHOOSING A SAVA PACKER VERSION	9
5.2.2. CHOOSING THE RIGHT SIZE OF SAVA PACKER	10
5.2.2.1. Diameter of SAVA packer	10
5.2.2.2. Length of SAVA packer	10
5.3. INFLATION SYSTEM FOR SAVA PACKERS	11
5.3.1. AIR SOURCE FOR INFLATION OF SAVA PACKERS	11
5.3.2. CONTROLLER FOR FILLING AND PRESSURE CONTROL OF SAVA PACKERS	12
5.3.3. INFLATION HOSES AND PUSH RODS	14
5.3.4. NON-STANDARD SAVA PACKERS	14
5.4. FIRST ASSEMBLY OF SAVA PACKERS	14
5.5. PROCEDURE FOR USE OF SAVA PACKERS	16
5.5.1. PROCEDURE FOR PREPARATION AND INSERTION OF SAVA PACKERS INTO A PIPE	16
5.5.1.1. Preparation of SAVA Pillow packer	22
5.5.2. PROCEDURE FOR PREPARATION AND INSERTION OF SAVA T PACKER IN A PIPE	24
5.6. UNEXPECTED SITUATIONS	32
5.7. ACCESSORIES	34
5.8. DISPOSAL OF WASTE MATERIAL	35

TABLE OF CONTENTS

6.0. MAINTENANCE AND CLEANING	35
6.1. SAFETY PRECAUTIONS	35
6.2. MAINTENANCE AND CLEANING AFTER USE	35
6.2.1. MAINTENANCE AND CLEANING OF SAVA PACKERS AFTER USE	35
6.2.1.1. Replacement of connecting coupling on the SAVA packer	36
6.2.1.2. Replacement of eyebolts on the SAVA packer	37
6.2.1.3. Replacement of the flow tube in SAVA flexible packers	37
6.2.2. MAINTENANCE OF SUPPLY AND CONNECTING HOSES AFTER USE	38
6.2.3. MAINTENANCE OF CONTROLLERS AFTER USE	38
6.3. PREVENTIVE MAINTENANCE	38
6.3.1. GENERAL	38
6.3.2. INSTRUCTIONS FOR SAFE WORK	38
6.3.2.1. Inspection of controllers	39
6.3.2.2. Inspection of connecting hoses	39
6.3.2.3. Inspection of SAVA packers	39
6.3.3. TEST PROCEDURES	40
6.3.3.1. Visual check of controllers	40
6.3.3.2. Tightness test of controllers	40
6.3.3.3. Function test of controllers	40
6.3.3.4. Visual check of connecting hoses	41
6.3.3.5. Tightness test and function test of connecting hoses	41
6.3.3.6. Visual check of SAVA packers	41
6.4. SERVICE LIFE	42
6.5. TROUBLESHOOTING AND REMEDY	43
7.0. WARRANTY CONDITIONS	44
7.1. GENERAL CONDITIONS	44
7.2. MANAGEMENT OF THE PRODUCTS	44
7.3. WARRANTY	44
7.4. EXCLUSION OF WARRANTY	44
7.5. MAKING A WARRANTY CLAIM	45
7.6. REMEDIES	45
7.7. CLOSING PROVISIONS	46

ATTACHMENTS

ATTACHMENT 1 - Technical data

ATTACHMENT 2 - Brief instructions for use of SAVA packers

ATTACHMENT 3 - Test report: Data on test item and test performance

1.0. IDENTIFICATION

1.1. TYPE OF PRODUCT

- Lateral packers HP-K
- Medusa packers
- 90° packers HP-T90°
- Flexible packers
- Long packers
- Short packers
- T packers
- Ultra flex advanced packers - UFAP packers
- Pillow packers

1.2. MANUFACTURER



Trelleborg SLOVENIJA, d.o.o.

Manufacturing and Marketing of Industrial Rubber Products and Tyres

Environmental Protection Products

Škofjeloška cesta 6
4502 Kranj
Slovenia

Tel: +386 (0)4 206 6388
Telefax: +386 (0)4 206 6390

info.eko@trelleborg.com
www.savatech.eu
www.savatech.com

2.0. PRODUCT DESCRIPTION

2.1. BASIC FUNCTIONS AND AREAS OF APPLICATION

SAVA packers are inflatable rubber products for rehabilitation of damaged pipelines by means of suitable resin-soaked fabric.

2.2. BASIC DATA

For basic data, please see the attached document Packers – Technical data.

2.3. ENVIRONMENTAL CONDITIONS AND RESTRICTIONS OF USE



WORKING TEMPERATURE RANGE	TEMPERATURES BELOW THE MINIMUM PERMISSIBLE VALUES	TEMPERATURES ABOVE THE MAXIMUM PERMISSIBLE VALUES
-20 do +80 °C (-4 do +176 °F)	-40 do -20 °C (-40 do -4 °F) up to 1h	80 do 90 °C (176 do 194 °F) up to 3 h



Standard version of SAVA packers is NOT suitable for use in potentially explosive atmospheres. Further information on special types of SAVA packers for use in potentially explosive atmospheres is available from the manufacturer or its official representative.

2.4. SAFETY AND PERSONAL PROTECTIVE EQUIPMENT

Always wear personal protective equipment when working with SAVA packers: protective helmet, goggles and gloves, as well as protective footwear and ear protection.



3.0. DEFINITIONS

Packer: Inflatable rubber tool for rehabilitation of damaged pipelines by means of resin-soaked fabrics.

By-pass packer: Packer that allows a controlled flow of liquid during its use.

Vacuuming (negative pressure): Controlled volume reduction of the product by creating negative pressure (vacuum) in it.

Working pressure: Prescribed pressure in the product during its use.

Controller: Device for filling, emptying and controlling the filling medium in the packer.

Safety valve : Pneumatic element for protecting the packer against excessive working pressure.

Connecting hose: Hose that connects the controller and packer.

Supply hose: Hose between the air source and controller.

Inflation hoses: Connecting and supply hoses needed for packer inflation.

Inlet coupling: Coupling on the controller for connection of supply hose.

Outlet connection: Connecting piece on the controller for connection of connecting hose.

Media: Substance in contact with the outer surface of the packer during use.

Pipe diameter: The inner diameter of the pipe, into which the packer is (will be) inserted.

Usage range: Work area of the packer defined with the minimum and maximum diameter of the pipe, in which the packer is inserted.

Contact surface: The surface of the packer in contact with the pipe, in which the packer is inserted.

Prescribed inflation pressure: Working pressure in the packer as prescribed by the manufacturer.

Hat of the packet: Metal or rubber part of the packer for assembly of the inflation connection and accessories.

Packer body : Rubber cylinder of the packer with caps on both ends.

T packer: Combination of the supporting packer and the hat mounted on that packer.

Eyebolt: Metal piece screwed on the packer cap for easier handling.

Protective foil: Foil for protection of rubber packer surface against resins.

4.0. PREPARATION OF PRODUCT FOR USE

4.1. TRANSPORT

SAVA packers are packed in cardboard boxes with their sensitive parts extra protected.

When not in use, the product should be stored in a dry and dark place at temperatures from 5 °C to 25 °C (41 °F to 77 °F).



Only exceptionally, SAVA packers may be under negative pressure (vacuumed) when transported. Immediately after transport, a plug must be inserted in the vacuumed SAVA packer to allow pressure in the packer to equalize with the external pressure, after which the packer restores its original shape.

4.2. SAFETY PRECAUTIONS BEFORE USE



These instructions must be read before using the product!



We recommend that all users of SAVA packers participate in a training course organised by the manufacturer or an authorised training service provider.

4.3. REMOVAL OF PACKAGING

Do not use sharp objects, such as knives, screwdrivers and similar, for removal of the packaging, as the product could get damaged.

4.4. DISPOSAL OF PACKAGING



The packaging is made of fully recyclable cardboard, which is why it should not be disposed of permanently. Dispose of packaging in waste bins for recycled paper or designated bins for cardboard packaging.

4.5. STORAGE AND PROTECTION OF PRODUCTS

When not in use, SAVA packers should be stored in a dry and dark space. During storage, they must not be vacuumed and folded.



Storage temperature: from +5 °C to +25 °C (41 °F to 77 °F).

Make sure that you only store clean packers, the inspection of which has proven they meet technical and safety requirements.

We recommend that SAVA packers are stored horizontally with their inflation connectors and eyebolts protected against mechanical damage.

4.6. STORAGE OF INSTRUCTIONS AND PERIODIC TEST REPORTS



The brief instructions and manufacturer test reports are enclosed with every SAVA packer. The full text of the instructions can be accessed on website at:
<https://www.savatech.com/manuals.html>



Keep the instructions and periodic test reports throughout the service life of the product!

5.0. INSTRUCTIONS FOR SAFE USE

5.1. RECOMMENDATIONS FOR SAFE AND EFFICIENT WORK



Non-compliance with the instructions may lead to a risk to users and third persons, and may cause various injuries, which is why the instructions must be read and understood prior to using the product!



- Always use the calibrated SAVA accessories of the prescribed working pressure rating.
- Do not use the product in the pipes of an inner diameter that exceeds that of the product.
- Never exceed the maximum inflation pressure.
- Continually check the pressure in the SAVA packer and adjust it as required.
- Improper use of SAVA packers is not allowed! The manufacturer is not liable for damage caused by improper use of the product.
- Always use the specified personal protective equipment when working with SAVA packers.
- An open flame and smoking are prohibited when working with SAVA packers.
- Standard version of SAVA packers is NOT suitable for use in potentially explosive atmospheres.



PRIOR TO USING SAVA PACKERS, READ THE INSTRUCTIONS CAREFULLY. THE RECOMMENDATIONS, REQUIREMENTS AND INSTRUCTIONS FOR USE OF PACKERS APPLY TO ALL SIZES AND TYPES OF SAVA PACKERS. THE INSTRUCTIONS MUST BE ACCESSIBLE TO ALL USERS OF SAVA PACKERS.

The instructions for the design, manufacture and control of the products made by Trelleborg Slovenija, d.o.o. always incorporate a high level of safety that is binding not only to the manufacturer but extends also to users. The user and the manufacturer must always comply with the instructions for safe and proper work during the use of SAVA packers.

Please read the instructions carefully. Should any doubts, questions or circumstances, not described in this manual, arise, consult a supervisor, responsible safety engineer, representative of the manufacturer or the manufacturer of SAVA packers.

5.1.1. Handling SAVA packers

Carry SAVA packers placed either vertically or horizontally. Make sure the inflation connector always faces upwards so that it cannot get damaged in case the product falls. The products not heavier than 20 kg (44 lbs) can be carried by one person, whereas heavier products of up to 40 kg (88 lbs) should be carried by at least two persons.

Use suitable lifting tools for carrying products heavier than 40 kg (88 lbs). The products are equipped with eyebolts for easier handling.

Warning: Eyebolts may be exposed to load in certain directions only. The load angle with respect to the axis of the eyebolt shall not exceed 45°. In Figure 1, the green arrows indicate the permitted load direction, while the red arrows indicate the unallowable direction.

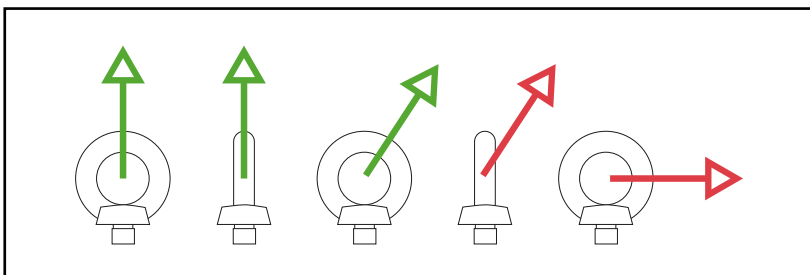

Figure 1: Load directions for eyebolts

5.1.2. WORKING ENVIRONMENT



TEMPERATURE OF CONTACT SURFACES

The product may only contact surfaces whose temperature does not exceed 80 °C (176 °F). Any higher temperature can permanently damage SAVA packers. The minimum temperature up to which SAVA packers maintain their usability is -20 °C -4 °F).



LIGHTING IN THE PLACE OF WORK

It is dangerous to work in the dark, even though SAVA packers are simple to position and inflate. Make sure that the place of work is properly illuminated and not in the shade. Do not use an open flame for lighting in the dark.



RESTRICTED AREA - AUTHORISED PERSONNEL ONLY

Only qualified personnel are allowed to be present in the working area with SAVA packers. All other persons should keep out of the working area. If additional risks are a threat to people and the environment, professional personnel must additionally carry out all the required precautionary actions to minimise such risks.



RESISTANCE TO THE MEDIA

SAVA packers are resistant to faeces and/or ordinary household wastewater. If the suspicion arises that non-standard chemicals are present, consult the manufacturer.

The use of various protective coatings – as an alternative to PVC foil for packer protection – is solely permitted with the consent of the manufacturer.

5.2. CHOOSING A SUITABLE SAVA PACKER

5.2.1. CHOOSING A SAVA PACKER VERSION

Please refer to Table 1 for choosing a suitable SAVA packer with regard to the conditions of use.

Table 1: Versions of SAVA packers with regard to the application conditions

CONDITIONS OF USE	SAVA PACKER VERSION
The pipe in which the packer will be used is straight or at an angle of up to 45 °. Unrestricted access to the pipe in which the packer will be used. No fluid flow through the pipeline is expected during the use of the packer. The pipe in which the packer will be used is not limited in longitudinal direction.	Lateral HP-K packer
The pipe in which the packer will be used is straight or at an angle of up to 45 °. Unrestricted access to the pipe in which the packer will be used. No fluid flow through the pipeline is expected during the use of the packer. The pipe in which the packer will be used is limited in longitudinal direction (pipe elbow or T-piece).	Medusa packer
The pipe in which the packer will be used is straight or at an angle of up to 45 °. Unrestricted access to the pipe in which the packer will be used.* Fluid flow through the pipeline is expected during the use of the packer.** The pipe in which the packer will be used is not limited in longitudinal direction.	Fleksibilni paker ** from size 15-25 on
The pipe in which the packer will be used is straight or at an angle of up to 45 °. Unrestricted access to the pipe in which the packer will be used.* No fluid flow through the pipeline is expected during the use of the packer. The pipe in which the packer will be used is not limited in longitudinal direction.	Long packers
Pipes of larger cross-sections. The pipe in which the packer will be used is straight. Unrestricted access to the pipe in which the packer will be used.* Fluid flow through the pipeline is expected during the use of the packer.	Short packers

CONDITIONS OF USE	SAVA PACKER VERSION
Rehabilitation of pipe elbows 45° - 90°. Unrestricted access to the pipe in which the packer will be used. No fluid flow through the pipeline is expected during the use of the packer. The pipe in which the packer will be used is not limited in longitudinal direction.	Packer HP-T90°
Rehabilitation of pipe elbows 45° - 90°. Unrestricted access to the pipe in which the packer will be used. No fluid flow through the pipeline is expected during the use of the packer. The pipe in which the packer will be used is limited in longitudinal direction (pipe elbow or T-piece).	Packer HP-T90° R
The pipe in which the packer will be used is straight or at an angle of up to 45°. Restricted access to the pipe in which the packer will be used. No fluid flow through the pipeline is expected during the use of the packer. The pipe in which the packer will be used is not limited in longitudinal direction.	UFAP packer
Pipes of larger cross-sections. The pipe in which the packer will be used is straight or at an angle of up to 45°. Restricted access to the pipe in which the packer will be used. No fluid flow through the pipeline is expected during the use of the packer. The pipe in which the packer will be used is not limited in longitudinal direction.	Pillow packer

* In the event of remote access, use the version with wheels.

5.2.2. CHOOSING THE RIGHT SIZE OF SAVA PACKER

5.2.2.1. Diameter of SAVA packer



Always choose the right size of SAVA packer!

The upper and lower usage range is defined for each SAVA packer. The nominal size of SAVA packer or the area in which the SAVA packer can be used is indicated on each SAVA packer.

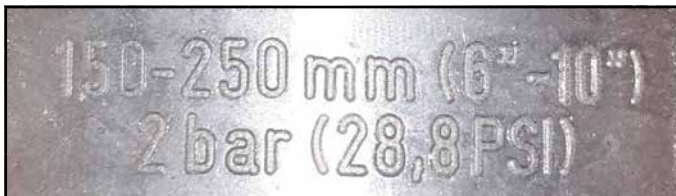

Prior to using the SAVA packer, always measure the inner diameter of the pipe, into which the packer will be inserted, and check whether the pipe diameter corresponds to the usage range of the packer.



DO NOT USE A SAVA PACKER IN A PIPE WHOSE DIAMETER IS SMALLER OR LARGER THAN THE USAGE RANGE.

5.2.2.2. Length of SAVA packer

When deciding on the length of SAVA packer, one should be familiar with the required contact length and the inner diameter of the pipe, in which the SAVA packer will be used. To roughly determine the required length of the product, you can use the formula:

$$l = L_w + \frac{\pi (D - d)}{2} + 12$$

l = calculated product length [cm]

L_w = required contact length [cm]

D = pipe diameter [cm]

d = diameter of the deflated product [cm]

Choose a SAVA packer that is longer than the length of the product calculated according to the above formula.

The approximate contact lengths are marked with white lines on the product, as shown in Figure 2. Due to the specific features of the rubber material, the position of the contact surface may change to a certain degree, which is why we recommend that, in limit cases, you choose a SAVA packer that is by one class longer.

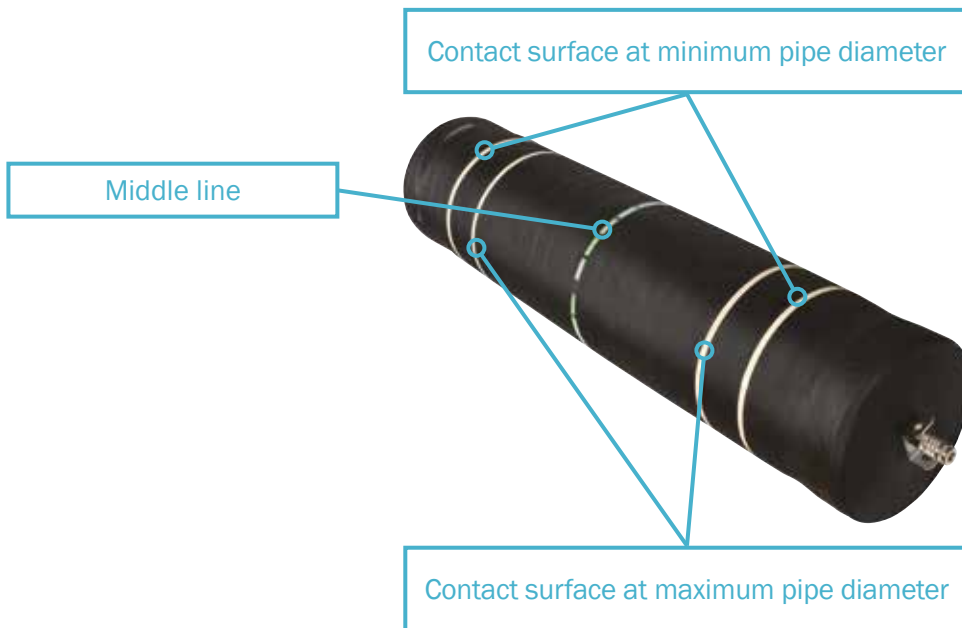

Figure 2: Contact surface markings

In case of packers HP-T90° and HP-T90° R only rehabilitation surface is marked.

The middle line (Figure 2) on the packer enables accuracy at application of the resin-soaked fabric on the SAVA packer.

5.3. INFLATION SYSTEM FOR SAVA PACKERS



- **SAVA packers may be inflated solely with air. In special cases, water is allowed for filling. The use of other gases and liquids is not allowed!**
- **Inflation without using SAVA controllers with built-in safety valves is not allowed!**

When using SAVA packers, observe the following combination:



This combination prevents SAVA packer from exceeding the permissible working pressure during the inflation.

5.3.1. AIR SOURCE FOR INFLATION OF SAVA PACKERS



The user is responsible for preparation of the air source and should further ensure that the maximum inlet pressure of the controller does not exceed the prescribed one.

Any air source that does not exceed the maximum inlet pressure of the controller (maximum pressure on the controller pressure gauge) can be used for inflation of SAVA packers. If the supply pressure of the air source is higher, use a pressure regulator. If the compressed air contains oil, use an oil separator.

WARNING: Oil vapours inside the SAVA packer can cause permanent damage that gradually leads to structural damage to the rubber body of the packer, in which case the product is no longer suitable for use.

5.3.2. CONTROLLER FOR FILLING AND PRESSURE CONTROL OF SAVA PACKERS

The controller is a pneumatic element designed for safe filling and pressure control during use and emptying of SAVA packers.



Figure 3: Controller 2.5 bar

The inlet safety coupling (Figure 4) is intended for connecting the supply hose. The safety coupling, by its design, prevents the supply hose from being disconnected by accident. To connect or disconnect the supply hose, rotate the locking ring of the safety coupling so that the notch on the ring engages with the screw, see the white circle in Figure 4. In this position, insert the supply hose connector into the safety coupling until it snaps into place. When disconnecting the supply hose, push the locking ring in the direction as shown with the blue arrow in Figure 4 and pull out the supply hose connector.

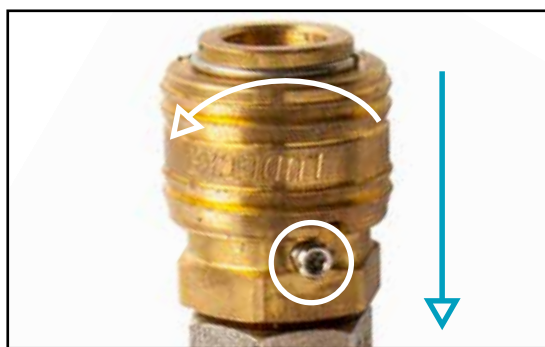

Figure 4: Safety coupling of the controller

The ball valve (Figure 3) is used for air intake into the SAVA packer. The ball valve is open and SAVA packer is filled when the ball valve lever is parallel to the inlet safety coupling. The safety valve must be closed. The ball valve is closed and SAVA packer does not fill when the ball valve lever is transverse to the safety coupling or in the position shown in Figure 3.

The controller pressure gauge (Figure 3) is designed to control the pressure in the SAVA packer.

WARNING: The correct pressure value can only be read with the controller ball valve closed.

The permitted pressure range of the SAVA packer is indicated in green on the pressure gauge scale. The working pressure value of the pressure gauge is indicated at the end of the green field.



The use of SAVA packers at working pressure values within or above the red area is prohibited.

An additional safety feature of the controller is a safety valve, which is set to 1.1× working pressure. If the working pressure is exceeded, the safety valve is activated and begins to reduce the pressure in the SAVA packer.



The flow-through of the safety valve upon activation is limited. In case of high-flow capacity air sources, it may happen that the activated safety valve does not completely interrupt the inflation of the SAVA packer but only slows it down. The activated safety valve emits a strong characteristic sound. When the safety valve is activated, the user must immediately close the ball valve on the controller to interrupt the filling of the SAVA packer.

The output connector of the controller serves for the connection of the controller and the SAVA packer by means of the supply hose.



The controller must remain connected to the SAVA packer throughout the inflation procedure and when the packer is pressurised.



Always use a controller of appropriate pressure rating and dimensions for SAVA packer inflation. Refer to Table 2 to select the appropriate controller.

Table 2: Table of controllers

PACKER LINE	WORKING PRESSURE OF SAVA PACKERS	CONTROLLER	CONTROLLER PART NO.	INLET CONNECTION	OUTLET CONNECTION
Lateral packers	3 bar (44psi)	Single controller 3.0 bar (44 psi)	537048	Safety coupling Type 26	Connector Type 26
	2.5 bar (36 psi)	Single controller 2.5 bar (36 psi)	60310	Safety coupling Type 26	Connector Type 26
Medusa packers	3 bar (44 psi)	Single controller 3.0 bar (44 psi)	537048	Safety coupling Type 26	Connector Type 26
	2.5 bar (36 psi)	Single controller 2.5 bar (36 psi)	60310	Safety coupling Type 26	Connector Type 26
Packers HP-T90 °	3 bar (44 psi)	Single controller 3.0 bar (44 psi)	537048	Safety coupling Type 26	Connector Type 26
	2.5 bar (36 psi)	Single controller 2.5 bar (36 psi)	60310	Safety coupling Type 26	Connector Type 26
Packers HP-T90 ° R	3 bar (44 psi)	Single controller 3.0 bar (44 psi)	537048	Safety coupling Type 26	Connector Type 26
	2.5 bar (36 psi)	Single controller 2.5 bar (36 psi)	60310	Safety coupling Type 26	Connector Type 26
Flexible Packers	2.5 bar (36 psi)	Single controller 2.5 bar (36 psi)	60310	Safety coupling Type 26	Connector Type 26
	2 bar (29 psi)	Single controller 2.0 bar (29 psi)	565643	Safety coupling Type 26	Connector Type 26
	1.5 bar (22 psi)	Single controller 1.5 bar (22 psi)	74609	Safety coupling Type 26	Connector Type 26
	1 bar (14.5 psi)	Single controller 1.0 bar (14.5 psi)	74653	Safety coupling Type 26	Connector Type 26
Long Packers	1.5 bar (22 psi)	Single controller 1.5 bar (22 psi)	74609	Safety coupling Type 26	Connector Type 26
	1 bar (14.5 psi)	Single controller 1.0 bar (14.5 psi)	74653	Safety coupling Type 26	Connector Type 26
Short Packers	2 bar (29 psi)	Single controller 2.0 bar (29 psi)	565643	Safety coupling Type 26	Connector Type 26
	1.5 bar (22 psi)	Single controller 1.5 bar (22 psi)	74609	Safety coupling Type 26	Connector Type 26
	1 bar (14.5 psi)	Single controller 1.0 bar (14.5 psi)	74653	Safety coupling Type 26	Connector Type 26
T Packers	2 bar (29 psi)	Single controller 2.0 bar (29 psi)	565643	Safety coupling Type 26	Connector Type 26
	1.5 bar (22 psi)	Single controller 1.5 bar (22 psi)	74609	Safety coupling Type 26	Connector Type 26
UFAP Packer	2 bar (29 psi)	Single controller 2.0 bar (29 psi)	565643	Safety coupling Type 26	Connector Type 26
	1.5 bar (22 psi)	Single controller 1.5 bar (22 psi)	74609	Safety coupling Type 26	Connector Type 26
Pillow paker	1.5 bar (22 psi)	Single controller 1.5 bar (22 psi)	74609	Safety coupling Type 26	Connector Type 26
	1 bar (14.5 psi)	Single controller 1.0 bar (14.5 psi)	74653	Safety coupling Type 26	Connector Type 26



To empty SAVA packers by means of the controller, unscrew the safety screw on the safety valve of the controller (Figure 5).

WARNING: After emptying is complete, retighten the safety screw on the safety valve, or else it will not be possible to use this controller for the next filling.

Figure 5: Unscrew the safety screw on controller safety valve

5.3.3. INFLATION HOSES AND PUSH RODS

Use inflation hoses or push rods of appropriate pressure and size class for inflation of SAVA packers. We recommend that you use standard SAVA hoses. The range of available hoses and their basic technical data are shown in Table 3.

Table 3: Table of connecting hoses

TYPE	PART NO.	LENGTH	COLOUR	INLET CONNECTION	OUTLET CONNECTION
Standard connecting hoses	74268	10 m (33')	Red	Safety coupling Type 26	Connector Type 26
	71248	10 m (33')	Blue		
	76686	10 m (33')	Yellow		
Poly lift connecting hoses	60957	5 m (16')	Blue	Safety coupling Type 26	Connector Type 26
	60958	10 m (33')	Blue		
Push rods	60491	1,5 m (5')	Grey	Safety coupling Type 26	Connector Type 26

5.3.4. NON-STANDARD SAVA PACKERS

Consult the manufacturer prior to using non-standard products.

5.4. FIRST ASSEMBLY OF SAVA PACKERS



SAVA packers are preassembled and ready for use, with the exception of flexible packers of size 20-30 (Figure 6). which need to be equipped with wheels

- For pipes of a diameter of up to 200 mm (8"): SAVA packers are preassembled.
- For pipes of a diameter of up to 250 mm (10"): Tighten the upper wheel on the small bracket and the bottom wheels on the large brackets.
- For pipes of a diameter of up to 300 mm (12"): Tighten the three wheels on the large brackets.

See Figure 7. Wheels (6 pieces). large brackets (6 pieces) and screws are enclosed.

Figure 6: Flexible packer 20-30

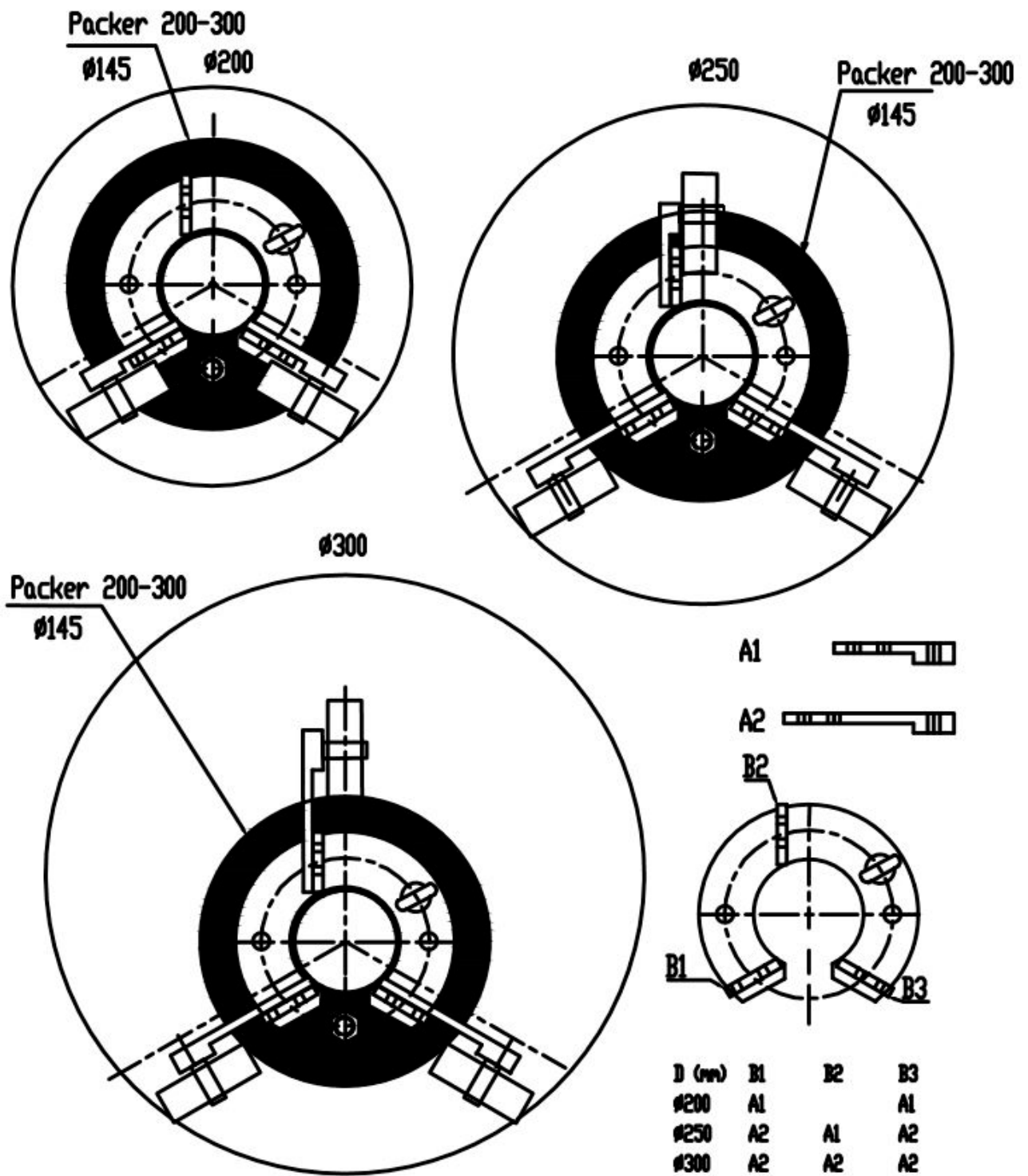

Figure 7: Outline of wheel assembly with a flexible packer 20-30

5.5. PROCEDURE FOR USE OF SAVA PACKERS

5.5.1. PROCEDURE FOR PREPARATION AND INSERTION OF SAVA PACKERS INTO A PIPE

Step 1:



Choose the right type and size of SAVA packer (Chapter 5.2).



To choose the right SAVA packer, always refer to the table of technical data and types of SAVA packers.

Step 2:

Prepare and carefully check before work: SAVA packer, air source, controller, inflation hoses.

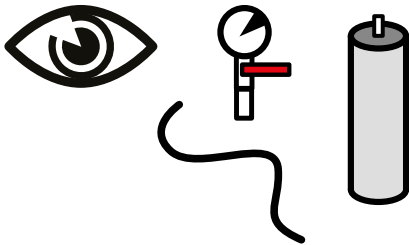

Damaged products or accessories are dangerous to use, so remove them from service and replace them.



If any doubts arise as to the safe use of SAVA packers and accessories, remove them and consult the manufacturer about further use.

Check the SAVA packer for ruptures, cuts and air pockets between the rubber layers, worn-out metal parts, damaged connectors, or any other damage.

The pressure gauge on the controller should be periodically calibrated.

Make sure you use only clean SAVA packers and accessories.

Step 3:

Thoroughly clean the pipe into which the SAVA packer will be inserted.

Prior to inserting the SAVA packer, the pipe must be properly cleaned. Remove any sharp particles to limit the risk of damage to the product.

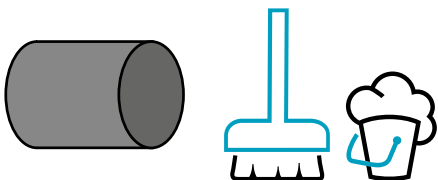



Even the smallest sharp particles, remaining after improper cleaning of the pipeline, can damage the SAVA packer permanently.

Step 4:

Connect the SAVA packer and the controller by means of a connecting hose.

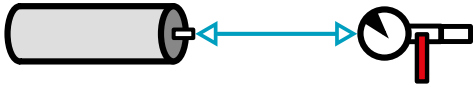

Step 5:

Connect the controller and the air source by means of a supply hose.

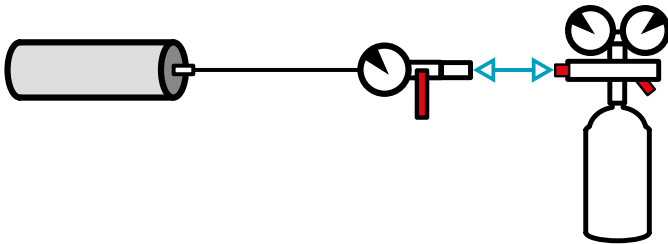

Step 6:

Check the pressure of the air source, see Chapter 5.3.1.

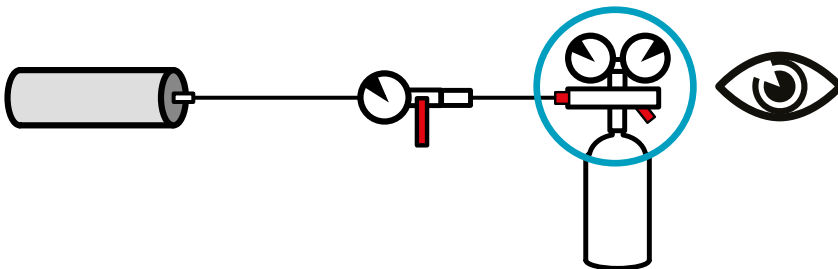

Step 7:

Open the ball valve on the controller and start filling the SAVA packer up to its basic position. (The SAVA packer is cylindrically shaped, not stretched but enough rigid for protective foil application).

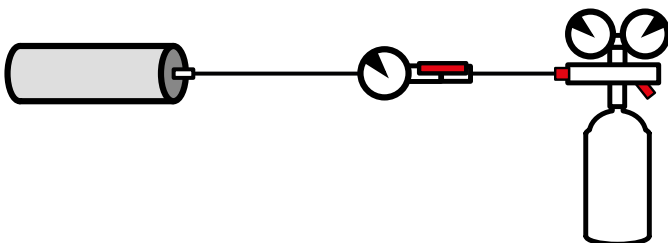

Always use a calibrated controller of suitable pressure rating for SAVA packer inflation. The controller safety valve must fully conform to the working pressure of the SAVA packer.

Step 8 :

Apply protective foil onto the SAVA packer.



Due to its specificity, the preparation of a Pillow packer is presented in more detail in Chapter 5.5.1.1.



Protective foil should be evenly applied over the entire surface of the SAVA packer.



Figure 8: Application of protective foil on SAVA packer

The main purpose of the protective foil is to protect the rubber body of the SAVA packer against the negative effects of resins used for pipeline rehabilitation.



It is not recommended to apply any substance directly on the packer as the packer might not be resistant to that respective substance.

Wrap the protective foil around the packer and ensure the entire surface is covered with at least one, however, not more than two layers of foil in order not to reduce the effective working pressure acting on the pipe during rehabilitation procedure.

If foil is wrapped unevenly or it covers the surface of the SAVA packer only partially, permanent deformation and collapse of the product may appear

Step 9:

Once protected, apply resin-soaked fibres on the SAVA packer.



Figure 9: Application of resin-soaked fibres on the protected SAVA packer



Comply with the instructions on use of resins for pipeline rehabilitation.

Step 10:

Insert the SAVA packer in the pipe; it should be positioned horizontally and in the middle of the pipe cross-section.



Figure 10: Insertion of SAVA packer into the pipe

When inserting the SAVA packer, make sure that its resin-coated surface does not drag across the pipe.

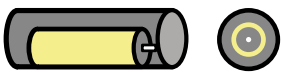

Observe the instructions for insertion as illustrated below.

Incorrect insertion of SAVA packers

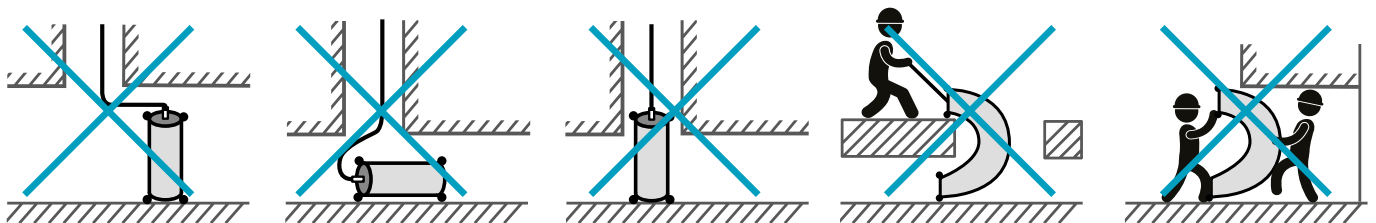

Correct insertion of SAVA packers

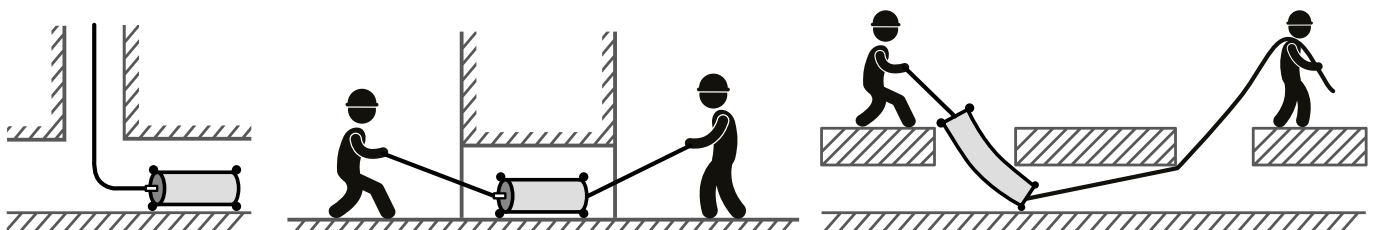

- 1. NEVER FILL THE SAVA PACKER OUTSIDE THE PIPE! The only exception is the specific procedures, which are separately presented in the instructions for use of SAVA packers.**
- 2. NEVER FILL THE SAVA PACKER IN AN UNCLEAN PIPE!**
- 3. THE SAVA PACKER MUST BE FULLY INSERTED IN THE PIPE!**

Step 11:

Inflate the SAVA packer.

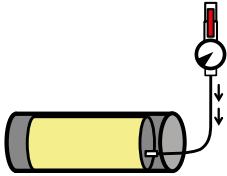

It is strictly prohibited to keep near the SAVA packer when it is pressurised!



Never exceed the nominal working pressure of the SAVA packer.

Check the pressure in the SAVA packer at intervals which are getting shorter with reducing the difference between the working pressure and the actual pressure in the SAVA packer.

WARNING: The actual pressure can only be read with the controller ball valve closed.



ONCE THE SAVA PACKER TIGHTLY PRESSES AGAINST THE INNER SURFACE OF THE PIPE, IT IS STRICTLY PROHIBITED TO EITHER STAY NEAR THE SAVA PACKER INSERTED IN THE PIPE OR NEAR THE PIPE OPENING. Failure to follow these instructions may result in injury or even death.

Step 12:

When the working pressure in the SAVA packer is reached, close the ball valve on the controller.

When the filling is stopped, a slight pressure drop in the SAVA packer due to its stretching can be noticed, which gradually decreases over time. Monitor the pressure constantly and adjust it if necessary.



The controller must remain connected to the SAVA packer throughout the inflation procedure and when the packer is pressurised.

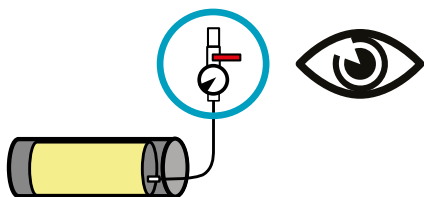

In the event of a pressure change, adjust the pressure in the SAVA packer to the required value; however, do not exceed the prescribed working pressure.



If unexpected situations arise during use of SAVA packers, stop work immediately and consult a supervisor or responsible safety engineer, who will determine the necessary actions to be taken.

Step 13:

Emptying the SAVA packer.

When the work is finished, relieve the pressure from the SAVA packer until it equals the external pressure and the SAVA packer gets its original, non-inflated, shape.

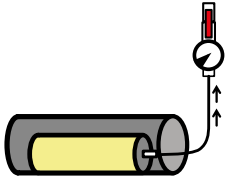

If the SAVA packer is not properly protected, it can stick to the hardened resin during rehabilitation. If the packer is removed from the pipe by force, it can get damaged.

Step 14:

Disconnect the air source, controller and connecting hose.

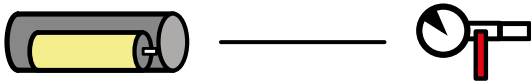

Step 15:

Remove the SAVA packer from the pipe.

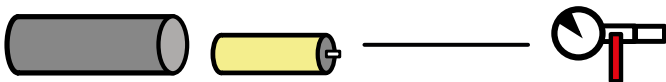

Remove the SAVA packer from the pipe only after it is completely empty. Avoid removing the SAVA packer by pulling on the connecting hose, as this can damage the SAVA packer or the connecting hose itself, which makes further use of SAVA packer or the accessories dangerous. Pull on the eyebolts instead.

Step 16:

Clean the deflated SAVA packer and accessories after use.

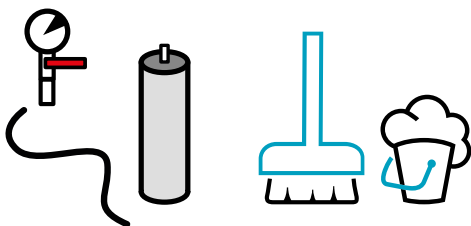

Comply with the instructions on cleaning and storing of SAVA packers.

Step 17:

Thoroughly check the SAVA packer, air source, controller and inflation hoses, and store them in accordance with the instructions for use.

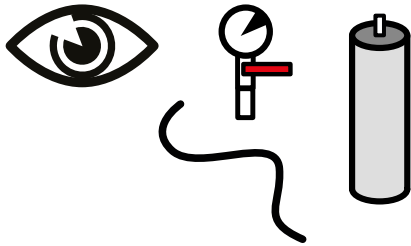

Damaged products or equipment are dangerous to use, which is why they should be removed from further use and replaced.



If any doubts arise as to the safe use of SAVA packers and equipment, remove them and consult the manufacturer about further use.

Check the SAVA packer for ruptures, cuts and air pockets between the rubber layers, worn-out metal parts, damaged connectors, or any other damage.

The pressure gauge on the controller should be periodically calibrated

5.5.1.1. Preparation of SAVA Pillow packer

Step 1:

Unfold the SAVA Pillow packer on a flat surface.

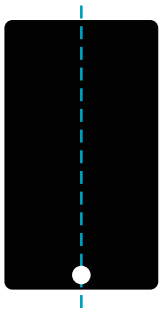

Step 2:

Protect the SAVA Pillow packer with protective foil.

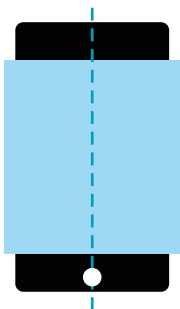

Step 3:

Apply fibres with resin onto the SAVA Pillow packer.

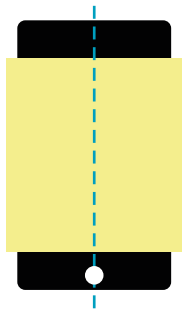

Step 4:

Fold the Pillow packer as illustrated.

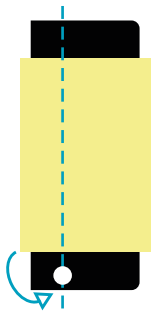

Step 5:

Fold the SAVA Pillow packer as illustrated.

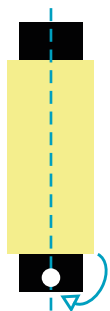

Step 6:

Fix the SAVA Pillow packer at several points with elastic bands as illustrated.



5.5.2. PROCEDURE FOR PREPARATION AND INSERTION OF SAVA T PACKER IN A PIPE

The supporting SAVA packer with a hat screwed on the rubber body is called SAVA T packer.

Step 1:



Choose the right SAVA T packer (Chapter 5.2).



To choose the right SAVA T packer, always refer to the table of technical data and types of SAVA packers.

Step 2:

Following the technical data table, choose the appropriate supporting SAVA packer and determine the right size of the hat to be fixed onto the supporting SAVA packer.

Step 3:

At the site of use, prepare and carefully check: SAVA T packer, air source, controller and inflation hoses.

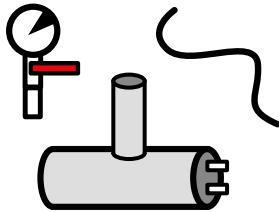

Damaged products or equipment are dangerous to use, which is why they should be removed from further use and replaced.



If any doubts arise as to the safe use of the SAVA packer and equipment, remove them from further use and consult the manufacturer about further use.

Check the SAVA T packer for ruptures, cuts and air pockets between the rubber layers, worn-out metal parts, damaged connectors, or any other damage.

The pressure gauge on the controller should be periodically calibrated.

Make sure that you use only clean SAVA T packer and accessories.

Step 4:

Thoroughly clean the pipe into which the SAVA T packer will be inserted.

To limit the risk of damage to the product, all sharp particles should be removed.

We recommend that you use high-pressure water cleaner for cleaning the pipe.

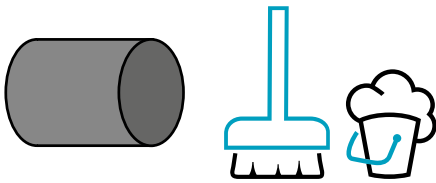

Even the smallest sharp particles, remaining after improper cleaning of the pipeline, can permanently damage the SAVA T packer.

Step 5a:

Using a connecting hose, connect the supporting SAVA packer and the hat with the controllers.

WARNING: The working pressure of the supporting SAVA packer is higher than that of the hat, which is why two different controllers are used. Make sure that the controller of the supporting SAVA packer is actually connected to the supporting SAVA packer and the controller of the hat to the hat (the coupling is marked red).

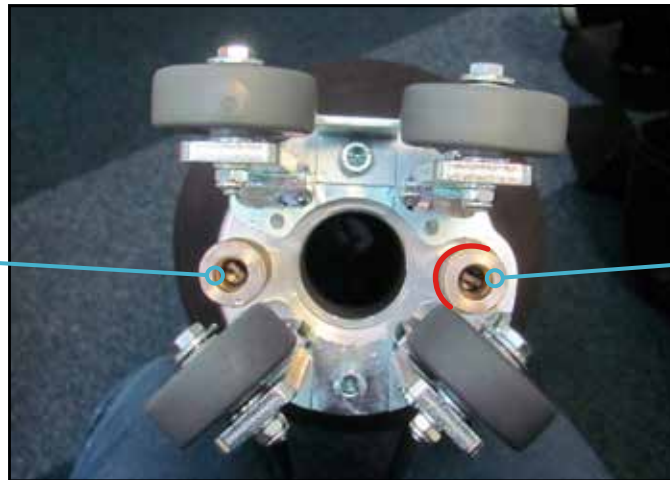
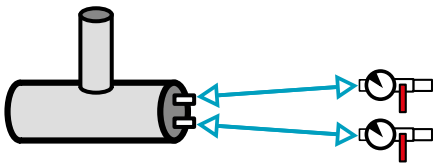

The left coupling for inflation of the supporting packer.

The right coupling, marked red, for inflation of the hat.

Step 5b:

Connect both controllers and the air source by means of a supply hose.

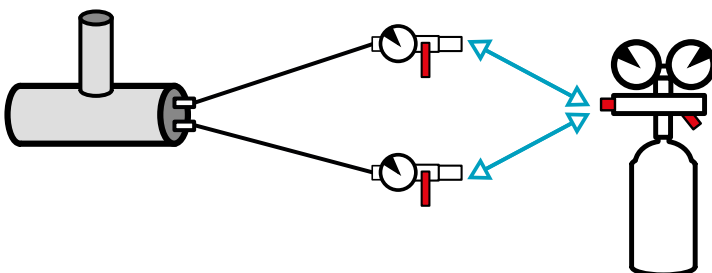

Step 5c:

Check the pressure of the air source, see Chapter 5.3.1.

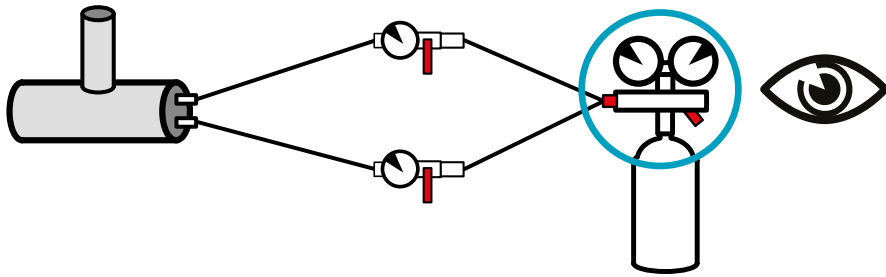

Step 5d:

Open the ball valve on the controller and start filling the supporting SAVA packer until it reaches its basic position (the SAVA packer is cylindrically shaped, not stretched but rigid enough for protective foil application).

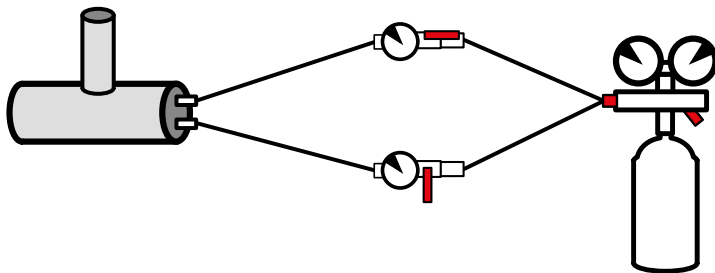

Fill SAVA T packers by means of controllers of corresponding pressure rating. The controller safety valves must fully conform to the working pressure of the supporting SAVA packer and/or the hat.

Step 6:

Apply protective foil onto the supporting SAVA packer.

Wrap the protective foil evenly around the packer to ensure that the entire surface is covered with at least one but not more than two layers of foil in order not to reduce the effective working pressure acting on the pipe during rehabilitation. If foil is wrapped unevenly or covers the SAVA packer surface only partially, the product may become permanently deformed.



Figure 11: Application of protective foil on SAVA packer



It is not recommended to apply any substance directly on the packer as it might not be resistant to that respective substance!

Step 7:

Screw the hat on the supporting SAVA packer as shown below.



Figure 13: Screw the hat on the SAVA packer Figure 13: Threaded insert M6

To screw the hat on the SAVA packer, a reducing adapter SW11 of R1/8" on M6 is needed; it is enclosed with the supporting SAVA packer. The threaded section should be sealed with a washer or Teflon sealing tape.

Step 8:

Attach the hat with foil on the supporting SAVA packer.



Figure 14: Fix the hat on the SAVA packer with foil

Step 9:

Prior to fixing the PVC protection onto the hat, spray a thin silicone layer on the hat.



Figure 15: Apply silicone layer on the hat

Step 10:

Place the PVC protection, which is by approximately 15 cm larger than the hat, on the hat. Ensure some free space above the hat as shown in Figure 16. Attach the rim of the hat with the PVC protection to the supporting SAVA packer. Fix both PVC-protected hat ends with rubber bands, adhesive tape or foil. Pierce the foil on the top of the hat to ensure proper venting.



Figure 16: Apply PVC protection on the hat

Step 11:

Once protected, apply resin-soaked fabric on the supporting SAVA packer.



Choose the right size of materials for rehabilitation. The size of the fabric should correspond to the dimension of the lateral pipe



Comply with the instructions on use of resins for pipeline rehabilitation.

Soak the fibres with resin and knead well to rub the resin in the fibres.



Figure 17: Apply resin-soaked fibres onto the protected SAVA T packer.

Step 12:

Place the soaked fibres on the SAVA T packer.



Figure 18: Apply resin-soaked fibres onto the protected SAVA T packer and fix them with rubber bands

- Wrap the lower part around the supporting SAVA packer and fix it with rubber bands.
- Attach the side part behind the hat.

Step 13:

Insert the SAVA T packer into the pipe. Prior to inserting, bend the hat in the opposite direction.



When inserting the SAVA packer, make sure that its resin-coated surface does not drag across the pipe.



Figure 19: Insert the SAVA T packer into the pipe

Position the SAVA T packer at the lateral connection as required.



The SAVA T packer should be positioned horizontally and in the middle of the pipe cross-section. Observe the instructions for insertion stated below.



Figure 20: Insert the SAVA T packer into the pipe and position it



Figure 21: Position the SAVA T packer in the pipe

Place the hat into the lateral connection and position it in the middle.

Incorrect insertion of SAVA T packers

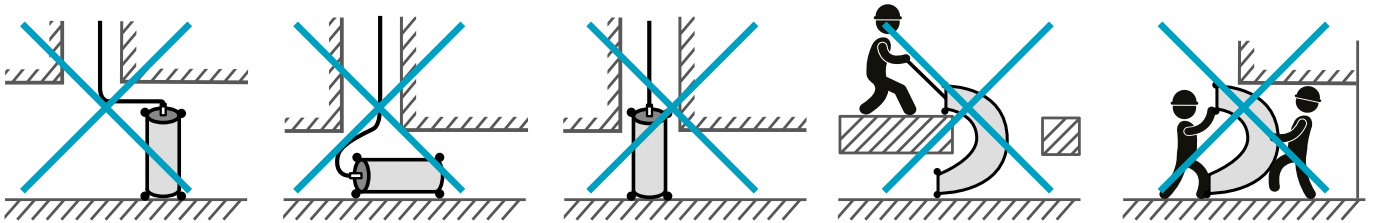

Correct insertion of SAVA T packers

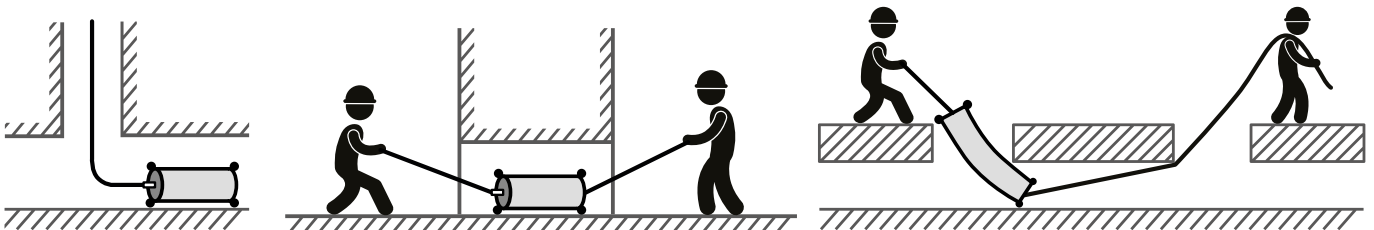

Step 14:

Comply with the filling sequence of SAVA T packers.

1. Slightly inflate the hat to position it as symmetrically to the lateral pipe and the supporting SAVA packer as possible.
2. Inflate the supporting SAVA packer so that a gap of about 2–3 cm is ensured between the supporting SAVA packer and the pipe wall.
3. Inflate the hat up to a pressure of 0.6 bar.
4. Inflate the supporting SAVA packer up to the nominal pressure.
5. Fill the hat up to the nominal pressure.



It is strictly prohibited to keep near the SAVA T packer when it is pressurised!



Never exceed the nominal working pressure in the hat.



The pressure in the hat may not exceed 80 % of the pressure value in the supporting SAVA packer.

Step 15:

Continually check the pressure in the supporting SAVA packer and the hat.

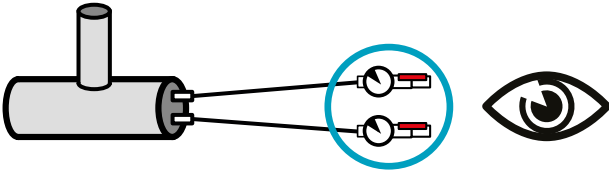

In the event of a pressure change, adjust the pressure in the supporting SAVA packer or the hat to the required value; however, make sure it does not exceed the prescribed working pressure.



Prior to emptying the SAVA T packer you must check if the back pressure has been entirely relieved. **EMPTYING THE SAVA PACKER UNDER BACK PRESSURE CAN BE DANGEROUS TO LIFE!**

Step 16:

When the work is finished, relieve the pressure in the hat.

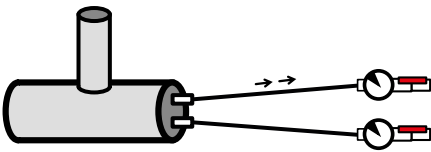

Step 17:

Relieve the pressure in the supporting SAVA packer and pull it out from the pipe.

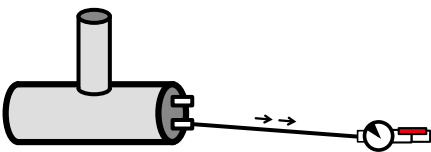

Prior to emptying the SAVA packer, relieve the back pressure if any.



DO NOT empty the supporting SAVA packer until the hat has been completely emptied.



Do not pull out the supporting SAVA packer until it has been completely emptied.



T paker SAVA se ob slabi zaščiti med saniranjem lahko prilepi na strjeno smolo. Ob uporabi sile pri izvlečenju, se izdelek lahko poškoduje.

Step 18:

Clean the deflated SAVA T paker (supporting SAVA paker and the hat) including the rest of accessories after use.

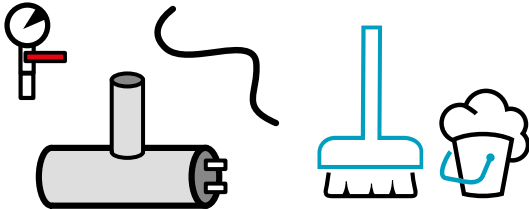

Comply with the instructions on cleaning and storing of SAVA T packers.

Step 19:

Thoroughly check the SAVA paker, the hat and the rest of accessories, and store them in accordance with the instructions for use.

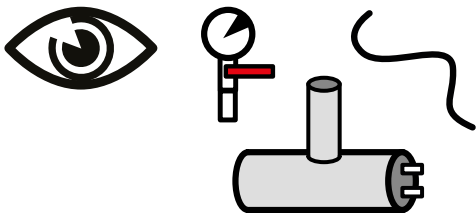

Damaged products or equipment should be removed from further use and replaced.



If any doubts exist as to the safe use of the SAVA T paker and equipment, remove them from use and consult the manufacturer about their further use.

Check the SAVA T paker for ruptures, cuts and air pockets between the rubber layers, worn-out metal parts, damaged connectors, or any other damage.

The pressure gauge on the controller should be periodically calibrated.

5.6. UNEXPECTED SITUATIONS



If, during work, you notice that SAVA packers, supply and connecting hoses, or any other components are damaged, which might compromise safety at work, immediately interrupt work and replace the damaged component. Working with SAVA packers and hoses that exhibit ruptures, bulges, unusual deformations and similar is NOT allowed.

If you consider the use of SAVA packers hazardous to people and objects, immediately stop the procedure. Consult a supervisor or a responsible safety engineer on further procedures.



A collapse of a SAVA packer is accompanied by a very loud bang.

Table 17: Unexpected situations

UNEXPECTED SITUATIONS	CONSEQUENCE	PROCEDURE
An uncontrolled pressure drop in the SAVA packer during rehabilitation. <i>Note: a slight pressure drop is usually due to stretching of the SAVA packer during inflation and it stops one minute after the inflation is interrupted.</i>	Pressure too low to enable successful pipe rehabilitation. Rehabilitation failed.	Try to maintain the required pressure during resin drying by way of controlled filling.
A short SAVA packer slips due to the excessive back pressure.	An uncontrolled and dangerous shift of SAVA packer due to the excessive back pressure. Damage to the SAVA packer.	 WARNING! The SAVA packer is just about to slip out completely. STAYING IN THE DIRECTION OF THE PIPE, IN WHICH THE SAVA PACKER IS INSERTED, IS DANGEROUS TO LIFE! Immediately start to relieve the back pressure.
The ball valve on the controller does not allow closing.	Pressure increase in the SAVA packer and, in extreme cases, its collapse.	1. Immediately close the air source. In case of pressure increase in the SAVA packer, the safety valve is activated and begins to reduce pressure in the SAVA packer or, in the event of high-capacity air source, it slows down the filling of the SAVA packer. 2. If back pressure is present, begin to relieve it. 3. Relieve the pressure from the SAVA packer. 4. Replace the controller.
The safety valve on the controller is activated.	The filling of the packer stops; the packer is exposed to excessive pressure. WARNING! If high-capacity air source is used, the safety valve will not interrupt the filling but only slow it down. The risk of product collapse due to excessive working pressure exists.	Immediately stop filling the SAVA packer and reduce the pressure to the prescribed value.
The pressure gauge on the controller stops functioning during work.	Safety at using the SAVA packer is not ensured.	1. Stop rehabilitation procedure. 2. Replace the controller.
Damage to the supply hose during work.	Failure to fill the SAVA packer.	1. Begin to deflate the SAVA packer. 2. Replace the supply hose.
Damage to the connecting hose during work – the hose leaks	Failure to fill the SAVA packer.	1. Begin to deflate the SAVA packer. 2. Replace the connecting hose.
When emptying the SAVA packer, the protective screw on the safety valve of the controller cannot be unscrewed.	Failure to empty the SAVA packer.	Disconnect the connecting hose from the controller very carefully. WARNING: THE HOSE IS UNDER PRESSURE AND WHILE DISCONNECTING IT, THE SAVA PACKER MAY MOVE UNEXPECTEDLY DUE TO BACK PRESSURE, AND CAUSE BRUISES.
Despite the loosened protective screw on the safety valve of the SAVA packer controller during emptying, the pressure in the SAVA packer does not drop. SAVA packer cannot be emptied.	Failure to empty the SAVA packer.	Disconnect the connecting hose from the controller very carefully. WARNING: THE HOSE IS UNDER PRESSURE AND WHILE DISCONNECTING IT, THE SAVA PACKER MAY MOVE UNEXPECTEDLY DUE TO BACK PRESSURE, AND CAUSE BRUISES.
Despite the disconnected connecting hose of SAVA packer during emptying, the pressure in the SAVA packer does not drop. Failure to empty the SAVA packer.	Failure to empty the SAVA packer.	 WARNING! DO NOT REACH INTO THE DANGER ZONE! Consult a supervisor, responsible safety engineer and/or representatives of the manufacturer of SAVA packers.

5.7. ACCESSORIES

Please refer to Table 5 for the entire range of accessories. Further information is available from the manufacturer or can be accessed on the manufacturer's website at: <http://www.savatech.com>

Table 5: List of accessories for use with SAVA packers

LATERAL PACKERS HP-K, MEDUSA PACKERS, 90° PACKERS HP-T90°	
537048	Single fitting controller, 3.0 bar (44 psi)
60310	Single fitting controller, 2.5 bar (36 psi)
74268	Inflation hose, 10 m (33'). red
71248	Inflation hose, 10 m (33'). blue
76686	Inflation hose, 10 m (33'). yellow
60491	Push rod, 1.5 m (5')
60957	Poly lift inflation hose, 5 m (16')
60958	Polly lift inflation hose, 10 m (33')
FLEXIBLE PACKERS	
60310	Single fitting controller, 2.5 bar (36 psi)
565643	Single fitting controller, 2.0 bar (29 psi)
74609	Single fitting controller, 1.5 bar (22 psi)
74653	Single fitting controller, 1.0 bar (14.5 psi)
74268	Inflation hose, 10 m (33'). red
71248	Inflation hose, 10 m (33'). blue
76686	Inflation hose, 10 m (33'). yellow
60491	Push rod, 1.5 m (5')
60957	Poly lift inflation hose, 5 m (16')
60958	Polly lift inflation hose, 10 m (33')
LONG PACKERS	
74609	Single fitting controller, 1.5 bar (22 psi)
74653	Single fitting controller, 1.0 bar (14.5 psi)
74268	Inflation hose, 10 m (33'). red
71248	Inflation hose, 10 m (33'). blue
76686	Inflation hose, 10 m (33'). yellow
60491	Push rod, 1.5 m (5')
60957	Poly lift inflation hose, 5 m (16')
60958	Polly lift inflation hose, 10 m (33')
SHORT PACKERS	
565643	Single fitting controller, 2.0 bar (29 psi)
74609	Single fitting controller, 1.5 bar (22 psi)
74653	Single fitting controller, 1.0 bar (14.5 psi)
74268	Inflation hose, 10 m (33'). red
71248	Inflation hose, 10 m (33'). blue
76686	Inflation hose, 10m (33'). yellow
60491	Push rod, 1.5 m (5')
60957	Poly lift inflation hose, 5 m (16')
60958	Polly lift inflation hose, 10 m (33')
T PACKERS	
565643	Single fitting controller, 2.0 bar (29 psi)
74609	Single fitting controller, 1.5 bar (22 psi)
74268	Inflation hose, 10 m (33'). red
71248	Inflation hose, 10 m (33'). blue
76686	Inflation hose, 10 m (33'). yellow
60491	Push rod, 1.5 m (5')
60957	Poly lift inflation hose, 5 m (16')
60958	Polly lift inflation hose, 10 m (33')

ULTRA FLEX ADVANCED PACKERS - UFAP PACKERS

565643	Single fitting controller, 2.0 bar (29 psi)
74609	Single fitting controller, 1.5 bar (22 psi)
74268	Inflation hose, 10 m (33'). red
71248	Inflation hose, 10 m (33'). blue
76686	Inflation hose, 10 m (33'). yellow
60957	Poly lift Inflation hose, 5 m (16')
60958	Poly lift Inflation hose, 10 m (33')

5.8. DISPOSAL OF WASTE MATERIAL



Damaged or worn-out products should be removed from use. SAVA packers are not ordinary but reusable waste and should be classified in accordance with the valid local regulations.

The product is partly recyclable.



The brief instructions for working with SAVA packers are enclosed with every product and also added at the back of these instructions. The instructions should be accessible to users of packers at all times.

6.0. MAINTENANCE AND CLEANING

6.1. SAFETY PRECAUTIONS



Use protective goggles, gloves and footwear when cleaning SAVA packers.

6.2. MAINTENANCE AND CLEANING AFTER USE

6.2.1. MAINTENANCE AND CLEANING OF SAVA PACKERS AFTER USE

Clean and carefully check SAVA packers after every use.

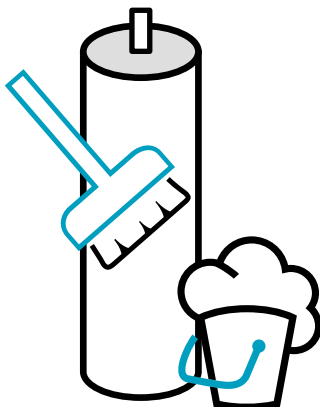

Remove the agglutinated dirt from the surface of SAVA packers with a brush with hard bristles. Move the brush in different directions. The use of sharp objects to remove dirt is not permitted.

Once the agglutinated dirt has been removed, wet the stains on the SAVA packer with a mild solution of dishwashing detergent and lukewarm water, and remove any remaining dirt from the surface with a hard bristle brush. Do not use petrol, diluter, alcohol or aggressive cleaning agents.

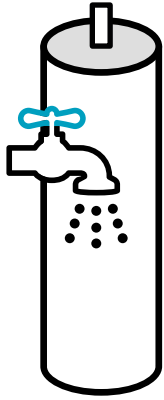

Rinse the SAVA packer with clean cold water. A strong water jet will remove any residual dirt and soap that may have remained on the surface of the SAVA packer.



High-pressure cleaners should NOT be used.



Never use solvents, hydrocarbons or other aggressive agents for cleaning SAVA packers. Using these agents can permanently damage or even destroy the SAVA packer.

Allow the SAVA packer to dry in a dark place. It must be completely dry before storing.



Do not dry SAVA packers in a drier or by means of heating devices.

Carefully examine the clean and dry SAVA packer, as follows:

- Check for air pockets, cuts and worn-out parts. Mark the damage or defect with chalk. Consult the manufacturer or its authorised representative about the severity of the damage and possibility for further use of SAVA packers.
- Check the connecting coupling. If damage prevents the connection of the connecting hose connector to the connecting coupling on the SAVA packer, replace the coupling.

6.2.1.1. Replacement of connecting coupling on the SAVA packer

To replace the connecting coupling, the following tools are required:

- spare coupling,
- open-end spanner of suitable size,
- Teflon adhesive tape or sealing adhesive,
- brush for soapy water application.

Using the open-end spanner, unscrew the coupling on the SAVA packer as shown in Figure 22.



Figure 22: Disassembly of connecting coupling

Apply thread sealing adhesive on the connecting coupling thread (Figure 23). Allow the adhesive to dry for at least 2 hours before use. You can also use Teflon sealing tape instead of thread sealing adhesive, in which case wrap Teflon sealing tape at least five times in clockwise direction as shown in Figure 24.



Figure 23: Application of Teflon adhesive tape

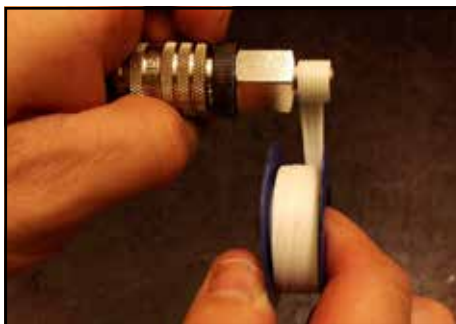

Figure 24: Application of sealing adhesive

Tighten the connecting coupling as shown in Figure 25.



Figure 25: Assembly of connecting coupling

Inflate the SAVA packer to $1.2 \times$ the minimum nominal diameter of the SAVA packer. Check for tightness between the connecting coupling and the flange with soapy water. In the event of leaks, unscrew and re-seal the coupling with adhesive or Teflon sealing tape.



Figure 26: Check for leaks after replacing the connecting coupling

6.2.1.2. Replacement of eyebolts on the SAVA packer

A damaged eyebolt should be removed and replaced with a new one. The technical characteristics of the new eyebolt must correspond to that of the original one.

6.2.1.3. Replacement of the flow tube in SAVA flexible packers

Instructions for replacing the flow tube in SAVA flexible packers are enclosed with a spare flow tube of the SAVA flexible packer.

6.2.2. MAINTENANCE OF SUPPLY AND CONNECTING HOSES AFTER USE

Clean the supply and connecting hoses with a mild solution of dishwashing detergent and lukewarm water after every use. Rinse the hoses with clean cold water.



High-pressure cleaners should NOT be used.

Check the opening in the connector and coupling. If the connector and the coupling are filled with dirt, remove it with a thin wire. Always pull dirt from the connector or coupling, do not push it into the hose.

Wipe the hoses with a dry cloth.



Do not dry supply and connecting hoses in a drier or by means of heating devices.

Carefully examine the clean and dry hoses, as follows:

- Check for cuts and worn-out parts. Mark the damage or defect with chalk. Consult the manufacturer or its authorised representative about the severity of the damage and possibility for further use of hoses.
- Check the connector. If damage prevents the connection with the connecting coupling on the hose, replace the hose.
- Check the coupling. If damage prevents the connection with the connector on the SAVA packer, replace the coupling

6.2.3. MAINTENANCE OF CONTROLLERS AFTER USE

Clean dirt from the controllers after use. Regularly inspect and check them for their proper functioning. Store the controllers in a dry, not dusty, place.

6.3. PREVENTIVE MAINTENANCE

6.3.1. GENERAL

Preventive maintenance, including testing, involves the inspection of SAVA packers with the associated accessories, the performance of tests and the replacement of damaged components to ensure user safety.

6.3.2. INSTRUCTIONS FOR SAFE WORK

Tests carried out under pressure may only be carried out after the entire system has been visually checked and no defects have been found.



If any doubt arises as to the safe test performance, immediately interrupt the test and consult the manufacturer or its authorised representative about further steps.

Always use personal protective equipment during checking and test performance. The use of a safety helmet, safety goggles, gloves, safety footwear and hearing protection is mandatory.

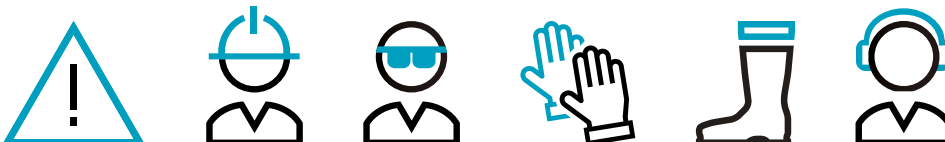

Tests should be performed outdoors (taking into account the appropriate safety distance between persons in the vicinity and the test item, as well as between buildings nearby). or in special-purpose enclosed spaces with appropriately reinforced construction, dedicated protection, pressure relief and out-of-test handling.



The performance of pressure tests is only allowed in pipes of appropriate dimensions whose strength conforms to the EN 13445-3 standard.



If, during testing, any damage or leaks of SAVA packers and/or damage and malfunctions of the equipment are identified, interrupt the test and DO NOT use these SAVA packers or accessories.

6.3.2.1. Inspection of controllers

TEST		CHECK-UP INTERVAL	TEST PERFORMANCE	PROCEDURE
1.	Visual check	<ul style="list-style-type: none"> • Before use • After every use • Annually 	A person qualified for operating SAVA packers	6.3.3.1.
2.	Tightness test	<ul style="list-style-type: none"> • After every use • Annually 	A person qualified for operating SAVA packers	6.3.3.2.
3.	Function test	<ul style="list-style-type: none"> • After every use • Annually 	A person qualified for operating SAVA packers	6.3.3.3.

6.3.2.2. Inspection of connecting hoses

TEST		CHECK-UP INTERVAL	TEST PERFORMANCE	PROCEDURE
1.	Vizualni pregled povezovalne cevi	<ul style="list-style-type: none"> • Before use • After every use • Annually 	A person qualified for operating SAVA packers	6.3.3.4.
2.	Test tesnosti in funkcionalni test povezovalne cevi	<ul style="list-style-type: none"> • After every use • Annually 	A person qualified for operating SAVA packers	6.3.3.5.

6.3.2.3. Inspection of SAVA packers

TEST		CHECK-UP INTERVAL	TEST PERFORMANCE	PROCEDURE	
1.	1.1.	Vizualni pregled nenapihnjenega pakerja SAVA	<ul style="list-style-type: none"> • Before use • After every use • Annually 	A person qualified for operating SAVA packers	6.3.3.6.1.
	1.2.	Vizualni pregled napihnjenega pakerja SAVA	<ul style="list-style-type: none"> • Before use • After every use • Annually 	A person qualified for operating SAVA packers	6.3.3.6.2.

6.3.3. TEST PROCEDURES

6.3.3.1. Visual check of controllers

Visually check for damage:

- inlet safety coupling,
- outlet connector,
- pressure gauges and pressure gauge indications,
- housing,
- protective cover of the pressure gauge.

6.3.3.2. Tightness test of controllers

The equipment required for performing the test:

- air source,
- soapy water and brush for application of soapy water.

Connect the controller to the air source and inflate it up to $0.5 \times$ working pressure. Check connecting points for leaks with soapy water. Visually check for tightness of all components of the controller.

6.3.3.3. Function test of controllers

The function test of the controller may only be performed if the controller has passed the tightness test. The function test consists of a pressure gauge test and a safety valve test.



The function test may be performed outdoors only while taking into account the safety distance between persons in the vicinity and the test item, as well as between buildings nearby and the test item.

FUNCTION TEST OF THE CONTROLLER PRESSURE GAUGE

The equipment required for performing the test:

- air source,
- reference pressure gauge of a higher accuracy class than the test item.

For the function test of the pressure gauge of the controller, use the reference pressure gauge, with the same measuring range like for the tested pressure gauge and of accuracy which is by one class higher than the one of the tested pressure gauge. Connect the reference pressure gauge and the tested pressure gauge in series to the pressure-adjustable air source. Gradually increase the pressure at the source and measure the deviation of the tested pressure gauge at three points (A, B, C):

- Point A: at about $1/3$ of nominal value of the controller
- Point B: at about $2/3$ of nominal value of the controller
- Point C: at the nominal value of the controller

If the deviation at any point exceeds the value of 5 % of the controller's nominal value, the tested pressure gauge is no longer appropriate for use.

FUNCTION TEST OF THE CONTROLLER SAFETY VALVE

The equipment required for performing the test:

- air source,
- reference pressure gauge of a higher accuracy class than the test item.

For the function test of the controller safety valve, connect the controller to the pressure-adjustable air source. Increase the pressure on the controller up to a maximum value of $1.3 \times$ working pressure or until the safety valve is activated (safety valve begins to leak). The safety valve is appropriate if activated within $(1.1 \pm 0.05) \times$ controller working pressure.

6.3.3.4. Visual check of connecting hoses

Visually check for damage:

- connecting couplings,
- connector,
- hoses.

If you notice ruptures, cuts, stiff areas due to contact with acids or any other damage, the connecting hose is no longer suitable for use.

6.3.3.5. Tightness test and function test of connecting hoses

The equipment required for performing the test:

- air source,
- controller,
- test vessel with water,
- soapy water and brush for soapy water application

Connect the connecting hose to the air source and fill it up to $0.5 \times$ working pressure. Use the stop coupling. Immerse the hose completely in the water and check it for leaks. Take the hose out of the water, dry it and apply soapy water over its surface and the connection points if necessary.

The function test of the connecting hose may only be performed if the connecting hose has passed the tightness test. Connect the connecting hose to the controller and gradually adjust the pressure in the hose up to the maximum pressure value of the pressure gauge. Close the valve at the air source and monitor the pressure drop on the controller pressure gauge. The hose is suitable for use if the pressure drop after 30 seconds does not exceed 5 % of the maximum pressure gauge value.

6.3.3.6. Visual check of SAVA packers



The test may be performed outdoors only while taking into account the safety distance between persons in the vicinity and the test item, as well as between buildings nearby and the test item.

6.3.3.6.1. Visual check of the non-inflated SAVA packer

Visually check the non-inflated SAVA packer for abnormal bulges, punctures, cuts or other mechanical damage. If necessary, apply soapy water over the entire surface of the SAVA packer, including the connection point and eyebolts if any. Visually check for leaks of the SAVA packer and the connection.

6.3.3.6.2. Visual check of the inflated SAVA packer

Inflate the SAVA packer (not applicable to Pillow packers) up to $1.2 \times$ the minimum nominal diameter of the selected SAVA packer. Visually check for any unusual bulges, punctures, cuts, or any other mechanical damage. If necessary, apply soapy water over the entire surface of the SAVA packer, including the connection point and eyebolts. Visually check for leaks of the SAVA packer and the inflation connection.

Inflate the SAVA Pillow packer up to the maximum nominal diameter, at which the pressure in the SAVA packer may not exceed 0.1 bar. Visually check for any unusual bulges, punctures, cuts, or any other mechanical damage. If necessary, apply soapy water over the entire surface of the SAVA packer, including the connection and eyebolts. Visually check for leaks of the SAVA packer and the inflation connection.

6.4. SERVICE LIFE

The service life of SAVA packers is 10 years provided they are used and maintained in accordance with the instructions.

The age of the SAVA packer can be identified by the serial number: the first two digits stand the month of manufacture while the second two digits stand for the year of manufacture.

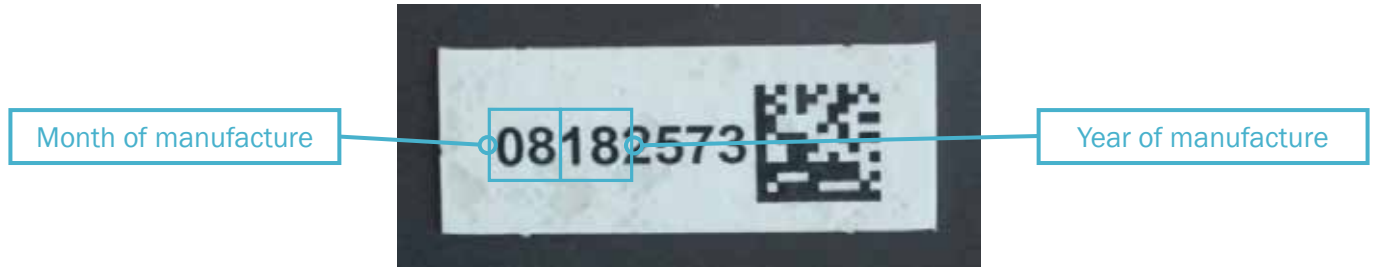

Figure 27: Serial number of SAVA packer

The example in the picture above shows the SAVA packer was made in August (08) in 2018 (18).



SAVA packers are made of rubber and therefore exposed to the natural aging process. Although a visual check shows the SAVA packer is still in good condition, it should be removed from use after 15 years, because the material structure could hide invisible signs of aging that cannot be seen with the naked eye.

6.5. TROUBLESHOOTING AND REMEDY

FAULT	REASON	REMEDY
Supply hose does not allow correct insertion in the controller connecting coupling.	Dirt in the connector or coupling. Connector or coupling damaged. Connector or coupling not compatible.	Clean the connector and coupling. Replace supply hose or controller. Check components for suitability.
Connecting hose does not allow correct insertion in the controller connecting coupling.	Dirt in the connector or coupling. Connector or coupling damaged. Connector or coupling not compatible.	Clean the connector and coupling. Replace hose or controller. Check components for suitability.
Controller ball valve is open but SAVA packer fails to fill.	Failure of safety valve. Protective screw on safety valve is loose. Connector or coupling blocked. Supply or connecting hose not properly connected. Supply or connecting hose damaged and leaking. Air source not functional.	Replace the controller. Tighten protective screw on safety valve. Clean the connector or coupling. Check and reconnect supply or connecting hose. Replace supply or connecting hose. Repair/replace air source.
During use, the pressure in SAVA packer begins to drop uncontrolled. <i>Note: a smaller pressure drop is a common consequence of the stretching of the SAVA packer during inflation and it stops a minute after interrupting the inflation.</i>	The pressure in SAVA packer leaks.	Z nadzorovanim polnjenjem poskušajte vzdrževati zahtevan tlak med procesom sušenja smole. Če to ni mogoče, sanacijo prikinite, paker SAVA vzemite iz cevi in ga zamenjajte z nadomestnim.
No flow through the by-pass tube of SAVA by-pass packer.	Liquid flow stopped.	1. Relieve pressure in SAVA packer. 2. Remove SAVA packer. 3. Clean the by-pass tube of SAVA packer. 4. Reinsert SAVA packer in the pipe and inflate it.
When SAVA packer is being emptied, the protective screw on controller safety valve cannot be unscrewed.	Protective screw on controller safety valve is mechanically blocked.	Carefully disconnect the connecting hose from the controller. WARNING: THE PIPE IS UNDER PRESSURE AND IT CAN MOVE UNEXPECTEDLY DURING DISCONNECTION, WHICH MAY CAUSE BRUISES. Replace the controller.
Despite disconnecting the connecting hose during emptying of SAVA packer, the pressure in SAVA packer does not drop. Failure to empty SAVA packer.	Connector on the connecting hose or coupling on SAVA packer is blocked.	 WARNING! Do not reach in the danger zone. Consult a supervisor, responsible safety engineer or a representative of the manufacturer of SAVA packers. Clean the connector on the connecting hose. Clean the coupling on SAVA packer.

7. WARRANTY CONDITIONS

7.1. GENERAL CONDITIONS

- 7.1.1. These warranty conditions apply as for Environmental protection and rescue products, manufactured by Trelleborg Slovenija, d.o.o. (hereinafter referred to as TBSLO). Product Area Environmental protection and rescue products (Products). If any provision of this warranty conditions would be contrary to any mandatory legal provisions in any particular jurisdiction, such provision shall apply to a maximum extent as provided for by such mandatory legal provisions.
- 7.1.2. Products which may be sold by TBSLO Product Area Environmental protection and rescue products but are not manufactured by it are not covered by this warranty and are sold exclusively with warranties, if any, by their original manufacturer.

7.2. MANAGEMENT OF THE PRODUCTS

- 7.2.1. In order to claim a remedy pursuant to this warranty, purchaser must conform to instructions for management of the Products, available at:
www.SAVA.eu/environmental-protection-and-rescue/manuals

7.3. WARRANTY

- 7.3.1. TBSLO warrants to the purchaser that for the period of twelve (12) months as of delivery of the Products, such Products shall be free from defects in material and workmanship, subject to normal and management of the Products, including, among others, proper storage. For high pressure lifting bags, the warranty period amounts to thirty-six (36) months as of delivery.
- 7.3.2. This warranty shall be in lieu of any other warranties, express or implied, including, but not limited to, any warranty of merchantability of fitness for a particular purpose.

7.4. EXCLUSION OF WARRANTY

- 7.4.1. Warranty shall be excluded in cases where the Products have not been used for the ordinary purpose or have been subject to abnormal conditions such as, but not limited to misuse, mishandling (such as, but not limited to, cuts, tears, vandalism, fire, wilful destruction, improper installation and/or improper maintenance, misapplication). use of unauthorized components or attachments or if adjustments or repairs have been performed by anyone other than TBSLO or its authorized agents.
- 7.4.2. Warranty shall also be excluded and TBSLO shall not be held liable in case of force majeure circumstances, such as, but not limited to:
- war or threat of war, sabotage, insurrection, riots or requisition;
 - all laws, restrictions, regulations, by-laws, prohibitions or any other measures by the governmental, parliamentary or local bodies;
 - import and export regulations or embargo;
 - strikes, lock-outs or other industrial measures or trade disputes (if including Manufacturer's employees or third party);
 - difficulties with supply of raw materials, work force, fuel, parts or machinery;
 - power blackout, break of machinery.

7.4.3. TBSLO shall not be held liable for any deficiencies in Products manufactured according to drawings, designs, project drafts and/or specifications provided by the purchaser.

7.4.4. Ordinary wear and tear are not covered by this warranty.

7.5. MAKING A WARRANTY CLAIM

7.5.1. Purchaser is obliged to take delivery of the Products and perform an ordinary inspection of the Product upon delivery.

7.5.2. Any claim by the purchaser with reference to the Products shall be deemed waived unless submitted in writing to TBSLO within the earlier of (I) eight days as of the discovery of the defect, or (II) twelve months as of the date of delivery of the Products or thirty-six (36) months as of delivery of high pressure lifting bags. Discovery of the defect is deemed to have occurred when a defect could have reasonably been detected by the purchaser.

7.5.3. Claim must at least contain the following data:

- part number,
- serial number,
- description of defect,

and must be substantiated by adequate evidence, such as pictures... Upon request, TBSLO must be allowed to inspect the Product.

7.5.4. To obtain performance under this warranty, any products suspected of having a manufacturing defect in materials or workmanship shall be returned freight prepaid for inspection to TBSLO, Product Area Environmental protection and rescue products, Škofjeloška c. 6, 4000 Kranj, Slovenia..

7.6. REMEDIES

7.6.1. TBSLO shall decide on a claim within forty -five days after receiving a complete documentation and Product pursuant to art 5.

7.6.2. Providing TBSLO acknowledges the claim as justified, it shall, at its discretion, either:

- repair the Product,
- replace those components of the Product which are defective,
- replace the Product, if repair is not possible or reasonable,
- reimburse the consideration for the Product or its components which are defective.

7.6.3. Whenever TBSLO repairs or replaces the Product at its expense or reimburses the purchase price, it shall reimburse the purchaser, with a credit note, the same surface freight amount the purchaser had when returning the Product to TBSLO.

7.6.4. Remedies pursuant to this article 6 shall constitute the sole and exclusive remedy in the event of a breach of warranty. For the avoidance of doubt, TBSLO shall not be liable for any incidental, consequential and/or non-pecuniary damages or damages having a comparable effect. TBSLO's aggregate liability in respect of any and all losses arising under or in connection to the contract/ purchase order/any similar document that is the basis for sale of Products, shall be limited to an amount equal to the invoiced price for the Products supplied. Any exclusions or limitations of liability are agreed to be extended for the benefit of all entities within TBSLO's group.

7.7. CLOSING PROVISIONS

- 7.7.1. No statement or action by Trelleborg Slovenija, whether express or implied, other than set forth herein, shall constitute a warranty.
- 7.7.2. Any applicability of general terms and conditions used by the purchaser, wherever stated, is hereby explicitly excluded, notwithstanding any provisions of such general terms and conditions to the contrary.
- 7.7.3. This warranty statement is subject to the laws of the Republic of Slovenia, with the exclusion of its conflict of law principles.

Kranj, January 2019



Trelleborg Slovenija, d.o.o.
PA Environmental protection products (PA EKO)

We are a division of Trelleborg Slovenija d.o.o..
We manufacture and sell rubber products for environmental protection and rescue operations and industrial use. Our growing division was established more than thirty years ago and is constantly striving to meet our customer's current and future needs and expectations.

WWW.SAVATECH.EU
WWW.SAVATECH.COM

Instructions for Use: Packers

Environmental protection products
phone: +386 (0)4 206 6388
e-mail: info.eko@savatech.si
fax: +386 (0)4 206 6390

Škofjeloška cesta 6, 4000 Kranj, Slovenia





Attachments to Instructions for use

ATTACHMENTS INDEX

ATTACHMENT 1: Technical data

ATTACHMENT 2: Brief instructions for use of SAVA packers

ATTACHMENT 3: Test report: data on test item and test performance

ATTACHMENT 1: Technical data

LATERAL PACKERS HP-K

Table 1: Lateral Packers HP-K – Technical data

PART NUMBER	NOMINAL SIZE	SIZE USAGE RANGE		REQUIRED INFLATION PRESSURE [bar] / [psi]	PRODUCT WEIGHT [kg] / [lbs]	RUBBER BODY LENGTH [mm] / [in]	DEFLATED PACKER	
		MIN. DIA. [mm] / [in]	MAX. DIA. [mm] / [in]				DIAMETER [mm] / [in]	LENGTH [mm] / [in]
529897	3.5-5 × 0.7 m / 1.4"-2" × 2.3'	35 / 1.4"	50 / 2"	3 / 44	0.4 / 1	700 / 28"	26 / 1"	765 / 30"
530785	3.5-5 × 1 m / 1.4"-2" × 3.3'	35 / 1.4"	50 / 2"	3 / 44	0.5 / 1	1000 / 40"	26 / 1"	1065 / 42"
530786	3.5-5 × 1.5 m / 1.4"-2" × 4.9'	35 / 1.4"	50 / 2"	3 / 44	0.7 / 2	1500 / 59"	26 / 1"	1565 / 62"
530787	3.5-5 × 2 m / 1.4"-2" × 6.6'	35 / 1.4"	50 / 2"	3 / 44	0.8 / 2	2000 / 79"	26 / 1"	2065 / 81"
538491	3.5-5 × 3 m / 1.4"-2" × 9.8'	35 / 1.4"	50 / 2"	3 / 44	1.1 / 2	3000 / 118"	26 / 1"	3065 / 121"
542187	5-7.5 × 0.7 m / 2"-3" × 2.3'	50 / 2"	75 / 3"	3 / 44	0.6 / 1	700 / 28"	30 / 1.2"	765 / 30"
281246	5-7.5 × 1 m / 2"-3" × 3.3'	50 / 2"	75 / 3"	3 / 44	0.7 / 2	1000 / 40"	30 / 1.2"	1065 / 42"
543422	5-7.5 × 1.5 m / 2"-3" × 4.9'	50 / 2"	75 / 3"	3 / 44	0.8 / 2	1500 / 59"	30 / 1.2"	1565 / 62"
543423	5-7.5 × 2 m / 2"-3" × 6.6'	50 / 2"	75 / 3"	3 / 44	1.1 / 2	2000 / 79"	30 / 1.2"	2065 / 81"
543431	5-7.5 × 3 m / 2"-3" × 9.8'	50 / 2"	75 / 3"	3 / 44	1.4 / 3	3000 / 118"	30 / 1.2"	3065 / 121"
60052	7-10 × 0.6 m / 3"-4" × 2'	70 / 3"	100 / 4"	2.5 / 36	0.6 / 1	600 / 24"	45 / 1.8"	720 / 28"
60053	7-10 × 1 m / 3"-4" × 3.3'	70 / 3"	100 / 4"	2.5 / 36	0.8 / 2	1000 / 40"	45 / 1.8"	1120 / 44"
60059	7-10 × 1.5 m / 3"-4" × 4.9'	70 / 3"	100 / 4"	2.5 / 36	1.1 / 2	1500 / 59"	45 / 1.8"	1620 / 64"
60060	7-10 × 2 m / 3"-4" × 6.6'	70 / 3"	100 / 4"	2.5 / 36	1.4 / 3	2000 / 79"	45 / 1.8"	2120 / 84"
559830	7-10 × 2.5 m / 3"-4" × 8.2'	70 / 3"	100 / 4"	2.5 / 36	1.6 / 4	2500 / 98"	45 / 1.8"	2620 / 103"
60061	7-10 × 3 m / 3"-4" × 9.8'	70 / 3"	100 / 4"	2.5 / 36	1.9 / 4	3000 / 118"	45 / 1.8"	3120 / 123"
60069	7-10 × 4 m / 3"-4" × 13.1'	70 / 3"	100 / 4"	2.5 / 36	2.4 / 5	4000 / 158"	45 / 1.8"	4120 / 162"
60081	7-10 × 5 m / 3"-4" × 16.4'	70 / 3"	100 / 4"	2.5 / 36	2.8 / 6	4900 / 193"	45 / 1.8"	5020 / 198"
60307	10-15 × 0.6 m / 4"-6" × 2'	100 / 4"	150 / 6"	2.5 / 36	1.1 / 2	600 / 24"	65 / 2.6"	720 / 28"
60308	10-15 × 1 m / 4"-6" × 3.3'	100 / 4"	150 / 6"	2.5 / 36	1.5 / 3	1000 / 40"	65 / 2.6"	1120 / 44"
60309	10-15 × 1.5 m / 4"-6" × 4.9'	100 / 4"	150 / 6"	2.5 / 36	1.9 / 4	1500 / 59"	65 / 2.6"	1620 / 64"
60311	10-15 × 2 m / 4"-6" × 6.6'	100 / 4"	150 / 6"	2.5 / 36	2.4 / 5	2000 / 79"	65 / 2.6"	2120 / 84"
60224	10-15 × 2.5 m / 4"-6" × 8.2'	100 / 4"	150 / 6"	2.5 / 36	2.8 / 6	2500 / 98"	65 / 2.6"	2620 / 103"
60461	10-15 × 3 m / 4"-6" × 9.8'	100 / 4"	150 / 6"	2.5 / 36	3.2 / 7	3000 / 118"	65 / 2.6"	3120 / 123"
60492	10-15 × 4 m / 4"-6" × 13.1'	100 / 4"	150 / 6"	2.5 / 36	4 / 9	4000 / 158"	65 / 2.6"	4120 / 162"
60298	10-15 × 5 m / 4"-6" × 16.4'	100 / 4"	150 / 6"	2.5 / 36	5.4 / 12	4900 / 193"	65 / 2.6"	5020 / 198"
60314	15-20 × 0.6 m / 6"-8" × 2'	150 / 6"	200 / 8"	2.5 / 36	1.9 / 4	600 / 24"	85 / 3.3"	720 / 28"
60330	15-20 × 1 m / 6"-8" × 3.3'	150 / 6"	200 / 8"	2.5 / 36	2.5 / 6	1000 / 40"	85 / 3.3"	1120 / 44"
60331	15-20 × 1.5 m / 6"-8" × 4.9'	150 / 6"	200 / 8"	2.5 / 36	3.1 / 7	1500 / 59"	85 / 3.3"	1620 / 64"
60343	15-20 × 2 m / 6"-8" × 6.6'	150 / 6"	200 / 8"	2.5 / 36	3.8 / 8	2000 / 79"	85 / 3.3"	2120 / 84"
60516	15-20 × 3 m / 6"-8" × 9.8'	150 / 6"	200 / 8"	2.5 / 36	5 / 11	3000 / 118"	85 / 3.3"	3120 / 123"
60955	15-20 × 4 m / 6"-8" × 13.1'	150 / 6"	200 / 8"	2.5 / 36	6.3 / 14	4000 / 158"	85 / 3.3"	4120 / 162"
60005	15-20 × 5 m / 6"-8" × 16.4'	150 / 6"	200 / 8"	2.5 / 36	8.6 / 19	4900 / 193"	85 / 3.3"	5020 / 198"
569503	15-25 × 0.6 m / 6"-10" × 2'	150 / 6"	250 / 10"	2.5 / 36	4.1 / 9	600 / 24"	105 / 4.1"	670 / 26"
569504	15-25 × 1 m / 6"-10" × 3.3'	150 / 6"	250 / 10"	2.5 / 36	4.8 / 10.6	1000 / 40"	105 / 4.1"	1070 / 42"
582122	15-25 × 1.5 m / 6"-10" × 4.9'	150 / 6"	250 / 10"	2.5 / 36	5.7 / 12.5	1500 / 59"	105 / 4.1"	1570 / 62"
569505	15-25 × 2 m / 6"-10" × 6.6'	150 / 6"	250 / 10"	2.5 / 36	6.5 / 14.3	2000 / 79"	105 / 4.1"	2070 / 81"
569506	15-25 × 3 m / 6"-10" × 9.8'	150 / 6"	250 / 10"	2.5 / 36	8.2 / 18.0	3000 / 118"	105 / 4.1"	3070 / 121"
569507	15-25 × 4 m / 6"-10" × 13.1'	150 / 6"	250 / 10"	2.5 / 36	9.8 / 21.6	4000 / 158"	105 / 4.1"	4070 / 160"
569508	15-25 × 5 m / 6"-10" × 16.4'	150 / 6"	250 / 10"	2.5 / 36	11.5 / 25.3	5000 / 193"	105 / 4.1"	5070 / 200"

MEDUSA PACKERS

Table 2: Medusa Packers – Technical data

PART NUMBER	NOMINAL SIZE	SIZE USAGE RANGE		REQUIRED INFLATION PRESSURE [bar] / [psi]	PRODUCT WEIGHT [kg] / [lbs]	RUBBER BODY LENGTH [mm] / [in]	DEFLATED PACKER	
		MIN. DIA. [mm] / [in]	MAX. DIA. [mm] / [in]				DIAMETER [mm] / [in]	LENGTH [mm] / [in]
529897	3.5-5 × 0.7 m / 1.4"-2" × 2.3'	35 / 1.4"	50 / 2"	3 / 44	0.4 / 1	700 / 28"	26 / 1"	765 / 30"
530785	3.5-5 × 1 m / 1.4"-2" × 3.3'	35 / 1.4"	50 / 2"	3 / 44	0.5 / 1	1000 / 40"	26 / 1"	1065 / 42"
530786	3.5-5 × 1.5 m / 1.4"-2" × 4.9'	35 / 1.4"	50 / 2"	3 / 44	0.7 / 2	1500 / 59"	26 / 1"	1565 / 62"
530787	3.5-5 × 2 m / 1.4"-2" × 6.6'	35 / 1.4"	50 / 2"	3 / 44	0.8 / 2	2000 / 79"	26 / 1"	2065 / 81"
538491	3.5-5 × 3 m / 1.4"-2" × 9.8'	35 / 1.4"	50 / 2"	3 / 44	1.1 / 2	3000 / 118"	26 / 1"	3065 / 121"
542187	5-7.5 × 0.7 m / 2"-3" × 2.3'	50 / 2"	75 / 3"	3 / 44	0.6 / 1	700 / 28"	30 / 1.2"	765 / 30"
281246	5-7.5 × 1 m / 2"-3" × 3.3'	50 / 2"	75 / 3"	3 / 44	0.7 / 2	1000 / 40"	30 / 1.2"	1065 / 42"
543422	5-7.5 × 1.5 m / 2"-3" × 4.9'	50 / 2"	75 / 3"	3 / 44	0.8 / 2	1500 / 59"	30 / 1.2"	1565 / 62"
543423	5-7.5 × 2 m / 2"-3" × 6.6'	50 / 2"	75 / 3"	3 / 44	1.1 / 2	2000 / 79"	30 / 1.2"	2065 / 81"
543431	5-7.5 × 3 m / 2"-3" × 9.8'	50 / 2"	75 / 3"	3 / 44	1.4 / 3	3000 / 118"	30 / 1.2"	3065 / 121"
60052	7-10 × 0.6 m / 3"-4" × 2'	70 / 3"	100 / 4"	2.5 / 36	0.6 / 1	600 / 24"	45 / 1.8"	720 / 28"
60053	7-10 × 1 m / 3"-4" × 3.3'	70 / 3"	100 / 4"	2.5 / 36	0.8 / 2	1000 / 40"	45 / 1.8"	1120 / 44"
60059	7-10 × 1.5 m / 3"-4" × 4.9'	70 / 3"	100 / 4"	2.5 / 36	1.1 / 2	1500 / 59"	45 / 1.8"	1620 / 64"
60060	7-10 × 2 m / 3"-4" × 6.6'	70 / 3"	100 / 4"	2.5 / 36	1.4 / 3	2000 / 79"	45 / 1.8"	2120 / 84"
559830	7-10 × 2.5 m / 3"-4" × 8.2'	70 / 3"	100 / 4"	2.5 / 36	1.6 / 4	2500 / 98"	45 / 1.8"	2620 / 103"
60061	7-10 × 3 m / 3"-4" × 9.8'	70 / 3"	100 / 4"	2.5 / 36	1.9 / 4	3000 / 118"	45 / 1.8"	3120 / 123"
60069	7-10 × 4 m / 3"-4" × 13.1'	70 / 3"	100 / 4"	2.5 / 36	2.4 / 5	4000 / 158"	45 / 1.8"	4120 / 162"
60081	7-10 × 5 m / 3"-4" × 16.4'	70 / 3"	100 / 4"	2.5 / 36	2.8 / 6	4900 / 193"	45 / 1.8"	5020 / 198"
60307	10-15 × 0.6 m / 4"-6" × 2'	100 / 4"	150 / 6"	2.5 / 36	1.1 / 2	600 / 24"	65 / 2.6"	720 / 28"
60308	10-15 × 1 m / 4"-6" × 3.3'	100 / 4"	150 / 6"	2.5 / 36	1.5 / 3	1000 / 40"	65 / 2.6"	1120 / 44"
60309	10-15 × 1.5 m / 4"-6" × 4.9'	100 / 4"	150 / 6"	2.5 / 36	1.9 / 4	1500 / 59"	65 / 2.6"	1620 / 64"
60311	10-15 × 2 m / 4"-6" × 6.6'	100 / 4"	150 / 6"	2.5 / 36	2.4 / 5	2000 / 79"	65 / 2.6"	2120 / 84"
60224	10-15 × 2.5 m / 4"-6" × 8.2'	100 / 4"	150 / 6"	2.5 / 36	2.8 / 6	2500 / 98"	65 / 2.6"	2620 / 103"
60461	10-15 × 3 m / 4"-6" × 9.8'	100 / 4"	150 / 6"	2.5 / 36	3.2 / 7	3000 / 118"	65 / 2.6"	3120 / 123"
60492	10-15 × 4 m / 4"-6" × 13.1'	100 / 4"	150 / 6"	2.5 / 36	4 / 9	4000 / 158"	65 / 2.6"	4120 / 162"
60298	10-15 × 5 m / 4"-6" × 16.4'	100 / 4"	150 / 6"	2.5 / 36	5.4 / 12	4900 / 193"	65 / 2.6"	5020 / 198"
60314	15-20 × 0.6 m / 6"-8" × 2'	150 / 6"	200 / 8"	2.5 / 36	1.9 / 4	600 / 24"	85 / 3.3"	720 / 28"
60330	15-20 × 1 m / 6"-8" × 3.3'	150 / 6"	200 / 8"	2.5 / 36	2.5 / 6	1000 / 40"	85 / 3.3"	1120 / 44"
60331	15-20 × 1.5 m / 6"-8" × 4.9'	150 / 6"	200 / 8"	2.5 / 36	3.1 / 7	1500 / 59"	85 / 3.3"	1620 / 64"
60343	15-20 × 2 m / 6"-8" × 6.6'	150 / 6"	200 / 8"	2.5 / 36	3.8 / 8	2000 / 79"	85 / 3.3"	2120 / 84"
60516	15-20 × 3 m / 6"-8" × 9.8'	150 / 6"	200 / 8"	2.5 / 36	5 / 11	3000 / 118"	85 / 3.3"	3120 / 123"
60955	15-20 × 4 m / 6"-8" × 13.1'	150 / 6"	200 / 8"	2.5 / 36	6.3 / 14	4000 / 158"	85 / 3.3"	4120 / 162"
60005	15-20 × 5 m / 6"-8" × 16.4'	150 / 6"	200 / 8"	2.5 / 36	8.6 / 19	4900 / 193"	85 / 3.3"	5020 / 198"
569503	15-25 × 0.6 m / 6"-10" × 2'	150 / 6"	250 / 10"	2.5 / 36	4.1 / 9	600 / 24"	105 / 4.1"	670 / 26"
569504	15-25 × 1 m / 6"-10" × 3.3'	150 / 6"	250 / 10"	2.5 / 36	4.8 / 10.6	1000 / 40"	105 / 4.1"	1070 / 42"
582122	15-25 × 1.5 m / 6"-10" × 4.9'	150 / 6"	250 / 10"	2.5 / 36	5.7 / 12.5	1500 / 59"	105 / 4.1"	1570 / 62"
569505	15-25 × 2 m / 6"-10" × 6.6'	150 / 6"	250 / 10"	2.5 / 36	6.5 / 14.3	2000 / 79"	105 / 4.1"	2070 / 81"
569506	15-25 × 3 m / 6"-10" × 9.8'	150 / 6"	250 / 10"	2.5 / 36	8.2 / 18.0	3000 / 118"	105 / 4.1"	3070 / 121"
569507	15-25 × 4 m / 6"-10" × 13.1'	150 / 6"	250 / 10"	2.5 / 36	9.8 / 21.6	4000 / 158"	105 / 4.1"	4070 / 160"
569508	15-25 × 5 m / 6"-10" × 16.4'	150 / 6"	250 / 10"	2.5 / 36	11.5 / 25.3	5000 / 193"	105 / 4.1"	5070 / 200"

90° PACKERS HP-T90°

Table 3: Packers HP-T90° – Technical data

PART NUMBER	NOMINAL SIZE	SIZE USAGE RANGE		REQUIRED INFLATION PRESSURE [bar] / [psi]	PRODUCT WEIGHT [kg] / [lbs]	RUBBER BODY LENGTH [mm] / [in]	DEFLATED PACKER	
		MIN. DIA. [mm] / [in]	MAX. DIA. [mm] / [in]				DIAMETER [mm] / [in]	LENGTH [mm] / [in]
281856	35-50 × 0.7 m / 1.4"-2" × 2.3'	35 / 1.4"	50 / 2"	3 / 44	0.8 / 1.8"	700 / 28"	26 / 1"	750 / 30"
558628	50-70 × 0.7 m / 2"-2.8" × 2.3'	50 / 2"	70 / 2.8"	2 / 29	0.7 / 1.5"	600 / 24"	30 / 1.2"	750 / 30"
281774	70-80 × 0.6 m / 2.8"-3" × 2'	70 / 2.8"	80 / 3"	2 / 29	0.8 / 1.8"	550 / 22"	45 / 1.8"	650 / 26"
525957	70-80 × 1 m / 2.8"-3" × 3.3'	70 / 2.8"	80 / 3"	2 / 29	0.9 / 2"	1000 / 40"	45 / 1.8"	1120 / 44"
525958	70-80 × 1.5 m / 2.8"-3" × 4.9'	70 / 2.8"	80 / 3"	2 / 29	1.2 / 3"	1500 / 59"	45 / 1.8"	1620 / 64"
578140	80-100 × 1 m / 3"-4" × 3'	80 / 3"	100 / 4"	2 / 29	2.5 / 5.5	1000 / 40"	65 / 2.6"	1120 / 44"
580365	80-100 × 1.5 m / 3"-4" × 4.9'	80 / 3"	100 / 4"	2 / 29	3.6 / 7.9"	1500 / 59"	65 / 2.6"	1620 / 64"
525960	100-125 × 1 m / 4"-5" × 3.3'	100 / 4"	125 / 5"	2 / 29	2 / 4"	1000 / 40"	65 / 2.6"	1120 / 44"
525961	100-125 × 1.5 m / 4"-5" × 4.9'	100 / 4"	125 / 5"	2 / 29	2.8 / 6"	1500 / 59"	65 / 2.6"	1620 / 64"
525963	150-165 × 1 m / 6"-6.5" × 3.3'	150 / 6"	165 / 6.5"	2 / 29	3.2 / 7"	1000 / 40"	85 / 3.3"	1120 / 44"
525964	150-165 × 1.5 m / 6"-6.5" × 4.9'	150 / 6"	165 / 6.5"	2 / 29	4.1 / 9"	1500 / 59"	85 / 3.3"	1620 / 64"
525959	180-205 × 1 m / 7"-8" × 3.3'	180 / 7"	205 / 8"	2 / 29	5.6 / 12"	1000 / 40"	105 / 4.1"	1120 / 44"
525962	180-205 × 1.5 m / 7"-8" × 4.9'	180 / 7"	205 / 8"	2 / 29	6.1 / 13"	1500 / 59"	105 / 4.1"	1620 / 64"
281628	200-250 × 1 m / 8"-10" × 3.3'	200 / 8"	250 / 10"	2 / 29	8.4 / 19"	1000 / 40"	130 / 5.1"	1120 / 44"
560617	200-250 × 1.5 m / 8"-10" × 4.9'	200 / 8"	250 / 10"	2 / 29	10.5 / 23"	1500 / 59"	130 / 5.1"	1620 / 64"
282151	250-350 × 1.5 m / 10"-14" × 4.9'	250 / 10"	350 / 14"	2 / 29	13.6 / 30"	1500 / 59"	140 / 5.5"	1620 / 64"

Table 4: Packers HP-T90°R – Technical data

PART NUMBER	NOMINAL SIZE	SIZE USAGE RANGE		REQUIRED INFLATION PRESSURE [bar] / [psi]	PRODUCT WEIGHT [kg] / [lbs]	RUBBER BODY LENGTH [mm] / [in]	DEFLATED PACKER	
		MIN. DIA. [mm] / [in]	MAX. DIA. [mm] / [in]				DIAMETER [mm] / [in]	LENGTH [mm] / [in]
579553	70-80 × 0.6 m / 2.8"-3" × 2'	70 / 2.8"	80 / 3"	2 / 29	0.8 / 1.8	600 / 24"	45 / 1.8"	630 / 25"
282182	70-80 × 1 m / 2.8"-3" × 3.3'	70 / 2.8"	80 / 3"	2 / 29	0.9 / 2	1000 / 40"	45 / 1.8"	1100 / 43"
574995	70-80 × 1.5 m / 2.8"-3" × 4.9'	70 / 2.8"	80 / 3"	2 / 29	1.2 / 3	1500 / 59"	45 / 1.8"	1600 / 63"
588405	80-100 × 1 m / 3"-4" × 3.3'	80 / 3"	100 / 4"	2 / 29	2.3 / 5.1	1000 / 40"	65 / 2.6"	1100 / 43"
588406	80-100 × 1.5 m / 3"-4" × 4.9'	80 / 3"	100 / 4"	2 / 29	2.7 / 5.9	1500 / 59"	65 / 2.6"	1600 / 63"
574211	100-125 × 1 m / 4"-5" × 3.3'	100 / 4"	125 / 5"	2 / 29	2 / 4	1000 / 40"	65 / 2.6"	1100 / 43"
578251	100-125 × 1.5 m / 4"-5" × 4.9'	100 / 4"	125 / 5"	2 / 29	2.8 / 6	1500 / 59"	65 / 2.6"	1600 / 63"
574212	150-165 × 1 m / 6"-6.5" × 3.8'	150 / 6"	165 / 6.5"	2 / 29	3.2 / 7	1000 / 40"	85 / 3.3"	1100 / 43"
578254	150-165 × 1.5 m / 6"-6.5" × 4.9'	150 / 6"	165 / 6.5"	2 / 29	4.1 / 9	1500 / 59"	85 / 3.3"	1600 / 63"
574213	180-205 × 1 m / 7"-8" × 3.3'	180 / 7"	205 / 8"	1.5 / 22	5.6 / 12	1000 / 40"	105 / 4.1"	1100 / 43"
578258	180-205 × 1.5 m / 7"-8" × 4.9'	180 / 7"	205 / 8"	1.5 / 22	6.1 / 13	1500 / 59"	105 / 4.1"	1600 / 63"

FLEXIBLE PACKERS

Table 5: Flexible Packers – Technical data

PART NUMBER	NOMINAL SIZE	SIZE USAGE RANGE		REQUIRED INFLATION PRESSURE [bar] / [psi]	PRODUCT WEIGHT [kg] / [lbs]	RUBBER BODY LENGTH [mm] / [in]	DEFLATED PACKER		BYPASS DIAMETER [FEMALE]
		MIN. DIA. [mm] / [in]	MAX. DIA. [mm] / [in]				TOTAL LENGTH [mm] / [in]	DIAMETER [mm] / [in]	
78214	10-15 × 1 m / 4"-6" × 3.3'	100 / 4"	150 / 6"	2.5 / 36	2.1 / 4.6	1000 / 39"	1080 / 43"	65 / 2.6"	NA
549589	10-15 × 1.5 m / 4"-6" × 4.9'	100 / 4"	150 / 6"	2.5 / 36	2.5 / 5.5	1500 / 59"	1580 / 62"	65 / 2.6"	NA
78266	10-15 × 2 m / 4"-6" × 6.6'	100 / 4"	150 / 6"	2.5 / 36	2.8 / 6.2	1900 / 75"	1980 / 78"	65 / 2.6"	NA
78218	10-15 × 2.5 m / 4"-6" × 8.2'	100 / 4"	150 / 6"	2.5 / 36	3.3 / 7.3	2500 / 98"	2580 / 102"	65 / 2.6"	NA
78231	10-15 × 3 m / 4"-6" × 9.8'	100 / 4"	150 / 6"	2.5 / 36	4.2 / 9.3	3000 / 118"	3080 / 121"	65 / 2.6"	NA
78244	10-15 × 4 m / 4"-6" × 13.1'	100 / 4"	150 / 6"	2.5 / 36	5 / 11	4000 / 158"	4080 / 161"	65 / 2.6"	NA
78283	10-15 × 5 m / 4"-6" × 16.4'	100 / 4"	150 / 6"	2.5 / 36	6 / 13	4900 / 193"	4980 / 196"	65 / 2.6"	NA
77240	15-25 × 1 m / 6"-10" × 3.3'	150 / 6"	250 / 10"	2 / 29	8 / 18	1000 / 39"	1210 / 48"	112 / 4.4"	2"
60853	15-25 × 1.5 m / 6"-10" × 4.9'	150 / 6"	250 / 10"	2 / 29	9.5 / 21	1500 / 59"	1710 / 67"	112 / 4.4"	2"
77614	15-25 × 2 m / 6"-10" × 6.6'	150 / 6"	250 / 10"	2 / 29	11 / 24	1900 / 75"	2110 / 83"	112 / 4.4"	2"
60846	15-25 × 2.5 m / 6"-10" × 8.2'	150 / 6"	250 / 10"	2 / 29	12.7 / 28	2500 / 98"	2710 / 107"	112 / 4.4"	2"
60497	15-25 × 3 m / 6"-10" × 9.8'	150 / 6"	250 / 10"	2 / 29	14.5 / 32	3000 / 118"	3210 / 126"	112 / 4.4"	2"
516143	15-25 × 3.5 / 6"-10" × 11.5'	150 / 6"	250 / 10"	2 / 29	15.8 / 35	3500 / 138"	3710 / 146"	112 / 4.4"	2"
60556	15-25 × 4 m / 6"-10" × 13.1'	150 / 6"	250 / 10"	2 / 29	17.4 / 38	4000 / 158"	4210 / 166"	112 / 4.4"	2"
60585	15-25 × 5 m / 6"-10" × 16.4'	150 / 6"	250 / 10"	2 / 29	21.4 / 47	4900 / 193"	5110 / 201"	112 / 4.4"	2"
569518	20-30 × 1 m / 8"-12" × 3.3'	200 / 8"	300 / 12"	1.5 / 22	11.3 / 25	1000 / 39"	1210 / 48"	145 / 5.7"	2"
569519	20-30 × 2 m / 8"-12" × 6.6'	200 / 8"	300 / 12"	1.5 / 22	13.3 / 29	2000 / 79"	2210 / 87"	145 / 5.7"	2"
569520	20-30 × 2.5 m / 8"-12" × 8.2'	200 / 8"	300 / 12"	1.5 / 22	14.3 / 32	2500 / 98"	2610 / 103"	145 / 5.7"	2"
569521	20-30 × 3 m / 8"-12" × 9.8'	200 / 8"	300 / 12"	1.5 / 22	15.2 / 34	3000 / 118"	3210 / 126"	145 / 5.7"	2"
569522	20-30 × 4 m / 8"-12" × 13.1'	200 / 8"	300 / 12"	1.5 / 22	17.2 / 38	4000 / 158"	4210 / 166"	145 / 5.7"	2"
569523	20-30 × 5 m / 8"-12" × 16.4'	200 / 8"	300 / 12"	1.5 / 22	19.1 / 42	4900 / 193"	5110 / 201"	145 / 5.7"	2"
77241	30-40 × 1 m / 12"-16" × 3.3'	300 / 12"	400 / 16"	1.5 / 22	19.2 / 42	1120 / 44"	1370 / 54"	210 / 8.3"	3"
514320	30-40 × 1.5 m / 12"-16" × 4.9'	300 / 12"	400 / 16"	1.5 / 22	21.6 / 48	1620 / 64"	1840 / 72"	210 / 8.3"	3"
77680	30-40 × 2 m / 12"-16" × 6.6'	300 / 12"	400 / 16"	1.5 / 22	25 / 55	2120 / 84"	2340 / 92"	210 / 8.3"	3"
60525	30-40 × 2.5 m / 12"-16" × 8.2'	300 / 12"	400 / 16"	1.5 / 22	30 / 66	2620 / 103"	2810 / 111"	210 / 8.3"	3"
60587	30-40 × 3 m / 12"-16" × 9.8'	300 / 12"	400 / 16"	1.5 / 22	33 / 73	3120 / 123"	3300 / 130"	210 / 8.3"	3"
60593	30-40 × 4 m / 12"-16" × 13.1'	300 / 12"	400 / 16"	1.5 / 22	41.5 / 92	4120 / 162"	4280 / 169"	210 / 8.3"	3"
60594	30-40 × 5 m / 12"-16" × 16.4'	300 / 12"	400 / 16"	1.5 / 22	47 / 104	4880 / 192"	5060 / 199"	210 / 8.3"	3"
77242	45-60 × 1 m / 18"-24" × 3.3'	450 / 18"	600 / 24"	1.2 / 17	34.5 / 76	1120 / 44"	1350 / 53"	340 / 13.4"	3"
517034	45-60 × 1.5 m / 18"-24" × 4.9'	450 / 18"	600 / 24"	1.2 / 17	36.6 / 81	1630 / 64"	1860 / 73"	340 / 13.4"	3"
78718	45-60 × 2 m / 18"-24" × 6.6'	450 / 18"	600 / 24"	1.2 / 17	41.6 / 92	2020 / 80"	2240 / 88"	340 / 13.4"	3"
60526	45-60 × 2.5 m / 18"-24" × 8.2'	450 / 18"	600 / 24"	1.2 / 17	50 / 110	2650 / 104"	2870 / 113"	340 / 13.4"	3"
78860	45-60 × 3 m / 18"-24" × 9.8'	450 / 18"	600 / 24"	1.2 / 17	53 / 117	3000 / 118"	3220 / 127"	340 / 13.4"	3"
65027	60-80 × 1.5 m / 24"-32" × 4.9'	600 / 24"	800 / 32"	1 / 15	46.8 / 103	1620 / 64"	1840 / 72"	400 / 15.7"	3"
60120	60-80 × 2 m / 24"-32" × 6.6'	600 / 24"	800 / 32"	1 / 15	52 / 115	2040 / 80"	2280 / 90"	400 / 15.7"	3"
60527	60-80 × 2.5 m / 24"-32" × 8.2'	600 / 24"	800 / 32"	1 / 15	61 / 135	2650 / 104"	2820 / 111"	400 / 15.7"	3"
60598	60-80 × 3 m / 24"-32" × 9.8'	600 / 24"	800 / 32"	1 / 15	65 / 143	2880 / 113"	3060 / 121"	400 / 15.7"	3"
78015	80-100 × 1.5 m / 32"-40" × 4.9'	800 / 32"	1000 / 40"	1 / 15	68.2 / 150	1540 / 61"	1780 / 70"	535 / 21.1"	4"
79186	100-120 × 2 m / 40"-48" × 6.6'	1000 / 40"	1200 / 48"	1 / 15	75 / 165	2000 / 79"	2240 / 88"	535 / 21.1"	4"

LONG PACKERS

Table 6: Long Packers– Technical data

PART NUMBER	NOMINAL SIZE	SIZE USAGE RANGE		REQUIRED INFLATION PRESSURE [bar] / [psi]	PRODUCT WEIGHT [kg] / [lbs]	RUBBER BODY LENGTH [mm] / [in]	DEFLATED PACKER	
		MIN. DIA. [mm] / [in]	MAX. DIA. [mm] / [in]				DIAMETER [mm] / [in]	LENGTH [mm] / [in]
541996	20-30 × 1 m / 8"-12" × 3.3'	200 / 8"	300 / 12"	1.5 / 22	4.9 / 11	1000 / 39"	145 / 5.7"	1100 / 43"
78256	20-30 × 1.5 m / 8"-12" × 4.9'	200 / 8"	300 / 12"	1.5 / 22	5.7 / 13	1500 / 59"	145 / 5.7"	1600 / 63"
67042	20-30 × 2 m / 8"-12" × 6.6'	200 / 8"	300 / 12"	1.5 / 22	6.5 / 14	2000 / 79"	145 / 5.7"	2100 / 83"
78257	20-30 × 2.5 m / 8"-12" × 8.2'	200 / 8"	300 / 12"	1.5 / 22	8.5 / 19	2500 / 98"	145 / 5.7"	2600 / 102"
77386	20-30 × 3 m / 8"-12" × 9.8'	200 / 8"	300 / 12"	1.5 / 22	10.8 / 24	3000 / 118"	145 / 5.7"	3100 / 122"
78258	20-30 × 4 m / 8"-12" × 13.1'	200 / 8"	300 / 12"	1.5 / 22	13.6 / 30	4000 / 158"	145 / 5.7"	4100 / 161"
77237	20-30 × 5 m / 8"-12" × 16.4'	200 / 8"	300 / 12"	1.5 / 22	18.4 / 41	4900 / 193"	145 / 5.7"	5000 / 197"
281323	30-40 × 1 m / 12"-16" × 3.3'	300 / 12"	400 / 16"	1.5 / 22	7.7 / 17	1000 / 39"	245 / 9.6"	1100 / 43"
78259	30-40 × 1.5 m / 12"-16" × 4.9'	300 / 12"	400 / 16"	1.5 / 22	13 / 29	1500 / 59"	245 / 9.6"	1600 / 63"
77925	30-40 × 2 m / 12"-16" × 6.6'	300 / 12"	400 / 16"	1.5 / 22	15.5 / 34	2000 / 79"	245 / 9.6"	2100 / 83"
77926	30-40 × 2.5 m / 12"-16" × 8.2'	300 / 12"	400 / 16"	1.5 / 22	16.7 / 37	2500 / 98"	245 / 9.6"	2600 / 102"
78260	30-40 × 3 m / 12"-16" × 9.8'	300 / 12"	400 / 16"	1.5 / 22	20 / 44	3000 / 118"	245 / 9.6"	3100 / 122"
78261	30-40 × 4 m / 12"-16" × 13.1'	300 / 12"	400 / 16"	1.5 / 22	26.3 / 58	4000 / 158"	245 / 9.6"	4100 / 161"
78262	30-40 × 5 m / 12"-16" × 16.4'	300 / 12"	400 / 16"	1.5 / 22	33.4 / 74	4900 / 193"	245 / 9.6"	5000 / 197"
560468	40-50 × 1 m / 16"-20" × 3.3'	400 / 16"	500 / 20"	1 / 15	18.9 / 42	1000 / 39"	340 / 13.4"	1100 / 43"
78263	40-50 × 1.5 m / 16"-20" × 4.9'	400 / 16"	500 / 20"	1 / 15	24.5 / 54	1500 / 59"	340 / 13.4"	1650 / 65"
77553	40-50 × 2 m / 16"-20" × 6.6'	400 / 16"	500 / 20"	1 / 15	27.7 / 61	2000 / 79"	340 / 13.4"	2150 / 85"
77239	40-50 × 2.5 m / 16"-20" × 8.2'	400 / 16"	500 / 20"	1 / 15	28 / 62	2500 / 98"	340 / 13.4"	2650 / 104"
78264	40-50 × 3 m / 16"-20" × 9.8'	400 / 16"	500 / 20"	1 / 15	30.5 / 67	3000 / 118"	340 / 13.4"	3100 / 122"
78265	40-50 × 4 m / 16"-20" × 13.1'	400 / 16"	500 / 20"	1 / 15	33 / 73	4000 / 158"	340 / 13.4"	4150 / 163"
77238	40-50 × 5 m / 16"-20" × 16.4'	400 / 16"	500 / 20"	1 / 15	38 / 84	5000 / 197"	340 / 13.4"	5150 / 203"
60179	50-60 × 1.5 m / 20"-24" × 4.9'	500 / 20"	600 / 24"	0.8 / 12	30 / 66	1500 / 59"	405 / 15.9"	1650 / 65"
67040	50-60 × 2 m / 20"-24" × 6.6'	500 / 20"	600 / 24"	0.8 / 12	34 / 75	2000 / 79"	405 / 15.9"	2150 / 84"
60190	50-60 × 2.5 m / 20"-24" × 8.2'	500 / 20"	600 / 24"	0.8 / 12	37.8 / 83	2500 / 98"	405 / 15.9"	2650 / 104"
70072	50-60 × 3 m / 20"-24" × 9.8'	500 / 20"	600 / 24"	0.8 / 12	40.8 / 90	3000 / 118"	405 / 15.9"	3150 / 124"
70218	50-60 × 4 m / 20"-24" × 13.1'	500 / 20"	600 / 24"	0.8 / 12	46 / 101	4000 / 158"	405 / 15.9"	4150 / 163"
70066	50-60 × 5 m / 20"-24" × 16.4'	500 / 20"	600 / 24"	0.8 / 12	51.5 / 114	5000 / 197"	405 / 15.9"	5150 / 203"
60758	60-80 × 1.5 m / 24"-32" × 4.9'	600 / 24"	800 / 32"	0.6 / 9	47 / 104	1500 / 59"	535 / 21.1"	1650 / 65"
60759	60-80 × 2 m / 24"-32" × 6.6'	600 / 24"	800 / 32"	0.6 / 9	51 / 112	1900 / 75"	535 / 21.1"	2050 / 81"
60760	60-80 × 2.5 m / 24"-32" × 8.2'	600 / 24"	800 / 32"	0.6 / 9	54.5 / 120	2500 / 98"	535 / 21.1"	2650 / 104"
60761	60-80 × 3 m / 24"-32" × 9.8'	600 / 24"	800 / 32"	0.6 / 9	58 / 128	3000 / 118"	535 / 21.1"	3150 / 124"
60763	60-80 × 4 m / 24"-32" × 13.1'	600 / 24"	800 / 32"	0.6 / 9	66 / 146	4000 / 158"	535 / 21.1"	4150 / 163"
60764	60-80 × 5 m / 24"-32" × 16.4'	600 / 24"	800 / 32"	0.6 / 9	75 / 165	5000 / 197"	535 / 21.1"	5150 / 203"

Table 7: Long Packers with wheels – Technical data

PART NUMBER	NOMINAL SIZE	SIZE USAGE RANGE		REQUIRED INFLATION PRESSURE [bar] / [psi]	PRODUCT WEIGHT [kg] / [lbs]	RUBBER BODY LENGTH [mm] / [in]	DEFLATED PACKER	
		MIN. DIA. [mm] / [in]	MAX. DIA. [mm] / [in]				DIAMETER [mm] / [in]	LENGTH [mm] / [in]
561419	20 - 30 × 1.5 m / 8"-12" × 4.9'	200 / 8"	300 / 12"	1.5 / 22	10.7 / 24	1500 / 59"	145 / 5.7"	1610 / 64"
569479	20 - 30 × 2 m / 8"-12" × 6.6'	200 / 8"	300 / 12"	1.5 / 22	11.7 / 26	2000 / 79"	145 / 5.7"	2110 / 83"
569480	20 - 30 × 2.5 m / 8"-12" × 8.2'	200 / 8"	300 / 12"	1.5 / 22	12.8 / 28	2500 / 98"	145 / 5.7"	2610 / 103"
569481	20 - 30 × 3 m / 8"-12" × 9.8'	200 / 8"	300 / 12"	1.5 / 22	14 / 31	3000 / 118"	145 / 5.7"	3110 / 122"
569482	20 - 30 × 4 m / 8"-12" × 13.1'	200 / 8"	300 / 12"	1.5 / 22	16 / 35	4000 / 158"	145 / 5.7"	4110 / 162"
569484	20 - 30 × 5 m / 8"-12" × 16.4'	200 / 8"	300 / 12"	1.5 / 22	18 / 40	5000 / 197"	145 / 5.7"	5110 / 201"
554829	30 - 40 × 1.5 m / 12"-16" × 4.9'	300 / 12"	400 / 16"	1.5 / 22	20 / 44	1500 / 59"	210 / 8.3"	1620 / 64"
563422	30 - 40 × 2 m / 12"-16" × 6.6'	300 / 12"	400 / 16"	1.5 / 22	23.6 / 52	2000 / 79"	210 / 8.3"	2120 / 83"
569485	30 - 40 × 2.5 m / 12"-16" × 8.2'	300 / 12"	400 / 16"	1.5 / 22	26 / 57	2500 / 98"	210 / 8.3"	2620 / 103"
569488	30 - 40 × 3 m / 12"-16" × 9.8'	300 / 12"	400 / 16"	1.5 / 22	30.5 / 67	3000 / 118"	210 / 8.3"	3120 / 123"
569489	30 - 40 × 4 m / 12"-16" × 13.1'	300 / 12"	400 / 16"	1.5 / 22	33.2 / 73	4000 / 158"	210 / 8.3"	4120 / 162"
569490	30 - 40 × 5 m / 12"-16" × 16.4'	300 / 12"	400 / 16"	1.5 / 22	38 / 84	5000 / 197"	210 / 8.3"	5120 / 202"
281493	40 - 50 × 1.5 m / 16"-20" × 4.9'	400 / 16"	500 / 20"	1 / 15	27 / 60	1500 / 59"	340 / 13.4"	1750 / 69"
569491	40 - 50 × 2 m / 16"-20" × 6.6'	400 / 16"	500 / 20"	1 / 15	30.2 / 67	2000 / 79"	340 / 13.4"	2250 / 89"
569492	40 - 50 × 2.5 m / 16"-20" × 8.2'	400 / 16"	500 / 20"	1 / 15	33.3 / 73	2500 / 98"	340 / 13.4"	2750 / 108"
569493	50 - 60 × 1.5 m / 20"-24" × 4.9'	500 / 20"	600 / 24"	0.8 / 12	40.4 / 89	1500 / 59"	400 / 16"	1760 / 69"
554830	50 - 60 × 2 m / 20"-24" × 6.6'	500 / 20"	600 / 24"	0.8 / 12	44.5 / 98	2000 / 79"	400 / 16"	2260 / 89"
569494	50 - 60 × 2.5 m / 20"-24" × 8.2'	500 / 20"	600 / 24"	0.8 / 12	48.2 / 106	2500 / 98"	400 / 16"	2760 / 109"
563790	60 - 80 × 1.5 m / 24"-32" × 4.9'	600 / 24"	800 / 32"	0.6 / 9	60 / 132	1500 / 59"	535 / 21.1"	1800 / 71"
569495	60 - 80 × 2 m / 24"-32" × 6.6'	600 / 24"	800 / 32"	0.6 / 9	65.5 / 144	2000 / 79"	535 / 21.1"	2300 / 91"

SHORT PACKERS

Table 8: Short Packers – Technical data

PART NUMBER	NOMINAL SIZE	SIZE USAGE RANGE		REQUIRED INFLATION PRESSURE [bar] / [psi]	PRODUCT WEIGHT [kg] / [lbs]	RUBBER BODY LENGTH [mm] / [in]	DEFLATED PACKER		BYPASS DIAMETER [mm] / [in]
		MIN. DIA. [mm] / [in]	MAX. DIA. [mm] / [in]				DIAMETER [mm] / [in]	LENGTH [mm] / [in]	
76646	15-20 × 0.8 m / 6"-8" × 2.6'	150 / 6"	200 / 8"	2 / 29	6.3 / 14	800 / 32"	115 / 4.5"	960 / 38"	80 / 3"
76647	25-30 × 0.8 m / 10"-12" × 2.6'	250 / 10"	300 / 12"	2 / 29	12.8 / 28	800 / 32"	205 / 8.1"	1010 / 40"	160 / 6"
76821	30-35 × 0.8 m / 12"-14" × 2.6'	300 / 12"	350 / 14"	1.5 / 22	17.2 / 38	800 / 32"	250 / 9.8"	1010 / 40"	200 / 8"
76648	35-40 × 0.8 m / 14"-16" × 2.6'	350 / 14"	400 / 16"	1.5 / 22	19.1 / 42	800 / 32"	305 / 12"	1010 / 40"	260 / 10"
76649	45-50 × 0.8 m / 18"-20" × 2.6'	450 / 18"	500 / 20"	1.5 / 22	29.7 / 66	800 / 32"	380 / 15"	1010 / 40"	325 / 13"
78247	60-70 × 0.97 m / 24"-28" × 3.2'	600 / 24"	700 / 28"	1 / 15	50.2 / 111	970 / 38"	465 / 18.3"	1180 / 47"	390 / 15"

T PACKERS

Table 9: T Packers (Main Packer) – Technical data

PART NUMBER	NOMINAL SIZE	SIZE USAGE RANGE		REQUIRED INFLATION PRESSURE [bar] / [psi]	PRODUCT WEIGHT [kg] / [lbs]	RUBBER BODY LENGTH [mm] / [in]	DEFLATED PACKER		BYPASS DIAMETER
		MIN. DIA. [mm] / [in]	MAX. DIA. [mm] / [in]				DIAMETER [mm] / [in]	LENGTH [mm] / [in]	
579609	20-25 × 0.8 m / 8"-10" × 2.6'	200 / 8"	250 / 10"	2 / 29	9 / 20	800 / 32"	112 / 4.4"	950 / 37"	2"
579610	25-30 × 0.8 m / 10"-12" × 2.6'	250 / 10"	300 / 12"	2 / 29	10 / 22	800 / 32"	145 / 5.7"	1000 / 40"	2"
579611	30-40 × 0.8 m / 12"-16" × 2.6'	300 / 12"	400 / 16"	2 / 29	18 / 40	800 / 32"	210 / 8.3"	1000 / 40"	3"

Table 10: T Packers (Hat) – Technical data

PART NUMBER	NOMINAL SIZE	DIAMETER OF THE HAT		SIZE USAGE RANGE		REQUIRED INFLATION PRESSURE [bar] / [psi]	PRODUCT WEIGHT [kg] / [lbs]	INFLATION VALVE
		BOTTOM DIA. [mm] / [in]	HAT HEIGHT [mm] / [in]	MIN. DIA. [mm] / [in]	MAX. DIA. [mm] / [in]			THREAD SIZE
590982	80-100 / 3"-4"	120 / 4.7"	140 / 5.5"	80 / 3"	100 / 4"	1.5 / 22	1.3 / 2.9	M6
585857	100-125 / 4"-5"	320 / 12.6"	190 / 7.5"	100 / 4"	125 / 5"	1.4 / 20	0.84 / 1.9	M6
585858	125-160 / 5"-6"	340 / 13.4"	210 / 8.3"	125 / 5"	160 / 6"	1.3 / 19	1.25 / 2.8	M6
585860	160-250 / 6"-10"	390 / 15.4"	220 / 8.7"	160 / 6"	250 / 10"	1.2 / 17	1.8 / 4	M6

ULTRA FLEX ADVANCED PACKERS - UFAP PACKERS

Table 11: Ultra flex advanced Packers – UFAP Packers – Technical data

PART NUMBER	NOMINAL SIZE	SIZE USAGE RANGE		REQUIRED INFLATION PRESSURE [bar] / [psi]	PRODUCT WEIGHT [kg] / [lbs]	RUBBER BODY LENGTH [mm] / [in]	DEFLATED PACKER	
		MIN. DIA. [mm] / [in]	MAX. DIA. [mm] / [in]				DIAMETER [mm] / [in]	LENGTH [mm] / [in]
590971	100 - 200 × 1 m / 4"-8" × 3.3'	100 / 4"	200 / 8"	2.0 / 29	1.9 / 4	1000 / 39"	55 / 2.2"	1120 / 44"
590972	100 - 200 × 1.5 m / 4"-8" × 4.9'	100 / 4"	200 / 8"	2.0 / 29	2.5 / 6	1500 / 59"	55 / 2.2"	1620 / 64"
590973	100 - 200 × 2 m / 4"-8" × 6.6'	100 / 4"	200 / 8"	2.0 / 29	3.1 / 7	2000 / 79"	55 / 2.2"	2120 / 84"
590974	100 - 200 × 3 m / 4"-8" × 9.8'	100 / 4"	200 / 8"	2.0 / 29	4.2 / 9	3000 / 118"	55 / 2.2"	3120 / 123"
590975	100 - 200 × 4 m / 4"-8" × 13.1'	100 / 4"	200 / 8"	2.0 / 29	5.3 / 12	4000 / 158"	55 / 2.2"	4120 / 162"
590976	100 - 200 × 5 m / 4"-8" × 16.4'	100 / 4"	200 / 8"	2.0 / 29	6.4 / 14	5000 / 197"	55 / 2.2"	5020 / 198"
590977	200 - 500 × 1.5 m / 8"-20" × 4.9'	200 / 8"	500 / 20"	1.5 / 22	11 / 24	1500 / 59"	160 / 6.3"	1600 / 63"
590978	200 - 500 × 2 m / 8"-20" × 6.6'	200 / 8"	500 / 20"	1.5 / 22	15.8 / 35	2000 / 79"	160 / 6.3"	2100 / 83"
590979	200 - 500 × 3 m / 8"-20" × 9.8'	200 / 8"	500 / 20"	1.5 / 22	19.9 / 44	3000 / 118"	160 / 6.3"	3100 / 122"
590980	200 - 500 × 4 m / 8"-20" × 13.1'	200 / 8"	500 / 20"	1.5 / 22	25.4 / 60	4000 / 158"	160 / 6.3"	4100 / 161"
590981	200 - 500 × 5 m / 8"-20" × 16.4'	200 / 8"	500 / 20"	1.5 / 22	30 / 66	4700 / 185"	160 / 6.3"	4800 / 189"









PILLOW PACKERS

Table 12: Pillow Packers – Technical data

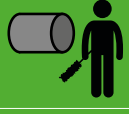
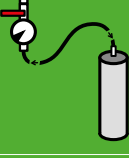
PART NUMBER	NOMINAL SIZE	SIZE USAGE RANGE		REQUIRED INFLATION PRESSURE [bar] / [psi]	PRODUCT WEIGHT [kg] / [lbs]	DEFLATED PACKER	
		MIN. DIA. [mm] / [in]	MAX. DIA. [mm] / [in]			DIAMETER [mm] / [in]	LENGTH [mm] / [in]
603323	40-60 × 2.5m / 15"-24" × 8.2'	400 / 15"	600 / 24"	1.5 / 22	23.8 / 52	2500 / 98"	600 / 23.4"
603325	60-100 × 3.26m / 24"-40" × 10.1'	600 / 30"	1000 / 36"	1 / 15	40 / 88	3260 / 128"	910 / 35.8"
603326	100-140 × 3.8m / 40"-55" × 12.5'	1000 / 40"	1400 / 48"	0.8 / 12	67.6 / 149	3800 / 150	1500 / 59"

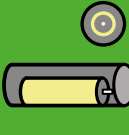
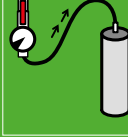
ATTACHMENT 2: Brief instructions for use of SAVA packers

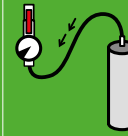
PACKERS

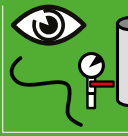
- | | | | |
|---------|--|---|--|
| Step 1 |  | PROCEDURE
Choose a suitable type and size of a SAVA packer. | WARNING
Always refer to the technical data tables and the required packer type for choosing a suitable SAVA packer. |
| Step 2 |  | PROCEDURE
Check and prepare at the site of use and rehabilitation: air source, packer, controller, supply hoses. | WARNING
Thoroughly check the SAVA packer and other equipment before use. It is dangerous to use any damaged products or equipment. Such products or equipment should be replaced and removed from further use. |
| Step 3 |  | PROCEDURE
Clean the pipe to be rehabilitated. | WARNING
Even the smallest sharp particles - due to not cleaning the pipeline properly - can permanently damage the SAVA packer. |
| Step 4 |  | PROCEDURE
Connect the air source and the controller to the SAVA packer and inflate it up to its basic position: cylindrically shaped but NOT elongated. | WARNING
Always use a controller of a suitable pressure rating for inflating the SAVA packer. The controller's safety valve should completely conform to the packer's working pressure. |
| Step 5 |  | PROCEDURE
Apply protective film on the SAVA packer. | WARNING
Protective film should be evenly applied across the entire surface of the packer. It is not recommendable to apply any grease on the packer as the packer might not be resistant to the applied grease! |
| Step 6 |  | PROCEDURE
Once protected, apply fibres and resin on the SAVA packer. | WARNING
Comply with the instructions on use of resins for pipeline rehabilitation. |
| Step 7 |  | PROCEDURE
Insert the SAVA packer in the pipe. | WARNING
When inserting the SAVA packer, make sure that its resin-coated surface does not drag across the pipe. Place the SAVA packer horizontally in the middle of the pipe cross-section. Observe the instructions for insertion stated below. |
| Step 8 |  | PROCEDURE
Inflate the SAVA packer up to its required pressure. | WARNING
Personnel are prohibited from entering the SAVA packer area when the packer is pressurized! Never exceed the nominal working pressure of the SAVA packer. |
| Step 9 |  | PROCEDURE
Continually check the pressure in the SAVA packer. | WARNING
If noticing a pressure change, adjust the pressure in the SAVA packer to the required value, however, never exceed the specified working pressure. |
| Step 10 |  | PROCEDURE
When the work is finished, release the back pressure in the packer and remove it from the pipe. | WARNING
Before emptying the SAVA packer, release the back pressure if any. Do not remove the SAVA packer until the air is completely vented from the packer. If the SAVA packer is not properly protected, it can stick to the hardened resin during rehabilitation. If forcibly removed from the pipe, the product can get damaged. |
| Step 11 |  | PROCEDURE
Clean and store the deflated SAVA packer and other equipment after use. Comply with the instructions. | WARNING
Comply with the instructions for cleaning and storing of SAVA packers. |
| Step 12 |  | PROCEDURE
Thoroughly check the SAVA packer and the rest of the equipment. | WARNING
Damaged products or equipment should be replaced and removed from further use. |



T-PACKERS

Step 1



PROCEDURE	WARNING
Choose a suitable type and size of a SAVA packer.	Always refer to the technical data tables and the required packer type for choosing a suitable SAVA packer.

Step 2



PROCEDURE	WARNING
Check and prepare at the site of use and rehabilitation: air source, packer, controller, supply hoses.	Thoroughly check the SAVA packer and other equipment before use. It is dangerous to use any damaged products or equipment. Such products or equipment should be replaced and removed from further use.

Step 3

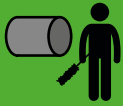

PROCEDURE	WARNING
Clean the pipe to be rehabilitated.	Even the smallest sharp particles - due to not cleaning the pipeline properly - can permanently damage the SAVA packer.

Step 4

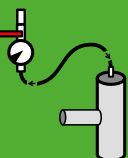

PROCEDURE	WARNING
Connect the air source and the controller to the SAVA packer and inflate it up to its basic position: cylindrically shaped but NOT elongated.	Always use a controller of a suitable pressure rating for inflating the SAVA packer. The controller's safety valve should completely conform to the packer's working pressure.

Step 5

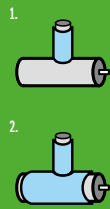

PROCEDURE	WARNING
Place a dedicated PVC protection on the hat. Apply protective film on the supporting SAVA packer and the hat being already protected with the dedicated PVC protection.	Protective film should be evenly applied across the entire surface of the packer and the hat. It is not recommendable to apply any grease on the packer as the packer might not be resistant to the applied grease!

Step 6



PROCEDURE	WARNING
Once protected, apply fibres with resin on the SAVA packer and the hat.	Comply with the instructions on use of resins for pipeline rehabilitation.

Step 7

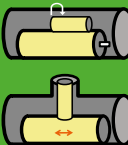

PROCEDURE	WARNING
Insert the SAVA packer in the pipe. Prior to the insertion, bend the hat in the opposite direction. Fine position the SAVA packer next to the lateral connection.	When inserting the SAVA packer, make sure that its resin-coated surface does not drag across the pipe. Place the SAVA packer horizontally in the middle of the pipe cross-section. Observe the instructions for insertion stated below.

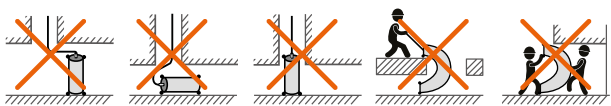

Step 8

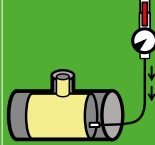

PROCEDURE	WARNING
Inflate the supporting SAVA packer up to its required pressure.	Personnel are prohibited from entering the SAVA packer area when the packer is pressurized! Never exceed the nominal working pressure of the SAVA packer.

Step 9

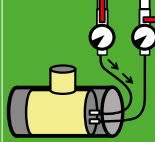

PROCEDURE	WARNING
Inflate the hat up to the required pressure.	Personnel are prohibited from entering the SAVA packer area when the packer is pressurized! Never exceed the nominal working pressure of the SAVA hat.

Step 10

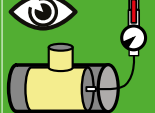

PROCEDURE	WARNING
Continually check the pressure in the supporting SAVA packer and the related hat.	If noticing a pressure change, adjust the pressure in the SAVA packer or hat to the required value, however, never exceed the specified working pressure.

Step 11

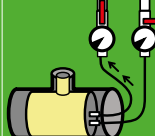

PROCEDURE	WARNING
When the work is finished, release the pressure in the hat.	If the SAVA hat packer is not properly protected, it can stick to the hardened resin during rehabilitation. If forcibly removed from the pipe, the product can get damaged.

Step 12

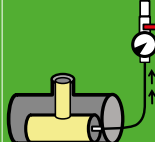

PROCEDURE	WARNING
Release the pressure in the supporting SAVA packer and remove it from the pipe.	Do not deflate the supporting SAVA packer until the air is completely vented from the hat. Before emptying the supporting SAVA packer, release the back pressure if any. If the supporting SAVA packer is not properly protected, it can stick to the hardened resin during rehabilitation. If forcibly removed from the pipe, the product can get damaged. Do not remove the supporting SAVA packer until the air is completely vented from the packer.

Step 13



PROCEDURE	WARNING
Clean and store the deflated SUPPORTING SAVA packer with the related hat and other equipment after use. Comply with the instructions.	Comply with the instructions for cleaning and storing of SAVA packers.

Step 14



PROCEDURE	WARNING
Thoroughly check the supporting SAVA packer with the related hat and the rest of the equipment.	Damaged products or equipment should be replaced and removed from further use.

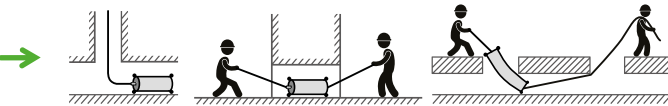



Non-compliance with the instructions for use can result in various injuries. Before using the product please read also full-text instructions for use as published at:



www.savatech.eu/environmental-protection-and-rescue/manuals

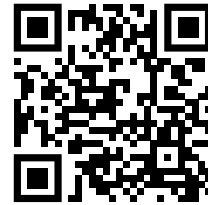

www.savatech.com/manuals



PERSONAL PROTECTIVE EQUIPMENT:

When operating the SAVA packers, always wear the proper personal protective equipment such as protective clothing, helmet, goggles gloves, footwear and ear protection.



WARNINGS:

Application temperature range: from -20 to +80 °C. The use of the product at temperatures below -20 °C, but not below -40 °C, is limited to 1 hour at the most, and at temperatures exceeding +80 °C to 30 minutes, however, the temperature may not exceed 100 °C.



The standard version of SAVA packers is **NOT** suitable for use in potentially explosive environments.



Open flame and smoking are forbidden when operating the SAVA packers.

CHOOSING A SUITABLE SAVA PACKER:

Refer to the technical data tables as well as product labels for choosing a suitable SAVA packer.



SAVA packers are not resistant to all types of chemicals. Please refer to the resistance table for rubber materials or consult the manufacturer on product properties.

ATTACHMENT 3: Test report: data on test item and test performance

VISUAL CHECK OF THE CONTROLLER

1	Coupling not damaged	YES	NO
2	Coupling functional	YES	NO
3	Valve functions smoothly	YES	NO
4	No visible faults on the valve	YES	NO
5	Protective cap of pressure gauge in place	YES	NO
6	No visible faults on controller housing	YES	NO
7	Permitted maximum pressure on pressure gauge marked	YES	NO
8	Pressure gauge glass not damaged	YES	NO
9	Connector not damaged	YES	NO
10	Connector functional	YES	NO
11	Other (specify)	YES	NO

TIGHTNESS TEST OF THE CONTROLLER

12	Controller leak-tight	YES	NO
13	Other (specify)	YES	NO

FUNCTION TEST OF CONTROLLER SAFETY VALVE

14	Safety valve not damaged	YES	NO
15	Safety valve activated as required	YES	NO
16	Loud sound upon activation of safety valve	YES	NO
17	Repeated visual check, no irregularities	YES	NO
18	Other (specify)	YES	NO

TIGHTNESS TEST AND FUNCTION TEST OF THE CONNECTING HOSE

19	Connecting hose attachable to the controller	YES	NO
20	Pressure in connecting hose adjusts when the controller lever is moved	YES	NO
21	Pressure drop after 30 seconds does not exceed the value of 10 % maximum pressure on the pressure gauge	YES	NO
22	Repeated visual check, no irregularities	YES	NO
23	Other (specify)	YES	NO

VISUAL CHECK OF THE NON-INFLATED SAVA PACKER

24	Range of use of SAVA packer readable	YES	NO
25	Serial number readable	YES	NO
26	Maximum working pressure of SAVA packer readable	YES	NO
27	Coupling on SAVA packer not damaged	YES	NO
28	Coupling on SAVA packer functional	YES	NO
29	Eyebolts on SAVA packer not damaged	YES	NO
30	No visible damage on SAVA packer	YES	NO
31	No visible cuts on SAVA packer	YES	NO
32	No visible ruptures on SAVA	YES	NO
33	No visible stiff areas on SAVA packer	YES	NO
34	No visible cord on SAVA packer surface	YES	NO
35	No visible consequences due to contact with chemicals on SAVA packer	YES	NO
36	No visible foreign particles on SAVA packer surface	YES	NO
37	SAVA packer not rotten	YES	NO
38	No visible signs of poor rubber-to-rubber bonding on SAVA packer	YES	NO
39	No visible signs of poor rubber-to-metal bonding on SAVA packer	YES	NO
40	Other (specify)	YES	NO

VISUAL CHECK OF THE INFLATED SAVA PACKER

41	Application range of SAVA packer readable	YES	NO
42	Serial number readable	YES	NO
43	Maximum working pressure of SAVA packer readable	YES	NO
44	Coupling on SAVA packer not damaged	YES	NO
45	Coupling on SAVA packer functional	YES	NO
46	Eyebolts on SAVA packer not damaged	YES	NO
47	Packer can be inflated up to a diameter that is by 20 % larger than the minimum nominal diameter	YES	NO
48	SAVA packer is inflated evenly	YES	NO
49	Cord thread spreading below 20%	YES	NO
50	Cap (cover or bottom) of SAVA packer not elliptically shaped by more than 5 %	YES	NO
51	SAVA packer leak-tight	YES	NO
52	No visible air pockets on SAVA packer	YES	NO
53	No visible damage on SAVA packer	YES	NO
54	No visible cuts on SAVA packer	YES	NO
55	No visible ruptures on SAVA packer	YES	NO
56	No visible stiff areas on SAVA packer	YES	NO
57	No visible cord on SAVA packer surface	YES	NO
58	No visible consequences due to contact with acids on SAVA packer	YES	NO
59	No visible consequences due to contact with chemicals on SAVA packer	YES	NO
60	No visible foreign particles on surface of SAVA packer	YES	NO
61	SAVA packer not rotten	YES	NO
62	No visible signs of poor rubber-to-rubber bonding on SAVA packer	YES	NO
63	No visible signs of poor rubber-to-metal bonding on SAVA packer	YES	NO
64	Other (specify)	YES	NO

TEST OF SAVA PACKER

Test itemt	SAVA PACKER		
Test date			
Date of last test			
Name of SAVA packer user			
Name of the person who performed the test			
Part no.	Serial no.	Year of manufacture	Notes

TEST RESULTS

Non-inflated SAVA packer has passed the visual inspection.	YES	NO
Inflated SAVA packer has passed the visual inspection.	YES	NO
SAVA packer has passed the test.	YES	NO

TEST EVALUATION

SAVA packer is suitable for further use.	YES	NO
SAVA packer is not suitable for further use.	YES	NO
Date/signature:		



Trelleborg Slovenija, d.o.o.
PA Environmental protection products (PA EKO)

We are a division of Trelleborg Slovenija d.o.o..
We manufacture and sell rubber products for environmental protection and rescue operations and industrial use. Our growing division was established more than thirty years ago and is constantly striving to meet our customer's current and future needs and expectations.

WWW.SAVATECH.EU
WWW.SAVATECH.COM

Instructions for Use: Packers

Environmental protection products
phone: +386 (0)4 206 6388
e-mail: info.eko@savatech.si
fax: +386 (0)4 206 6390

Škofjeloška cesta 6, 4000 Kranj, Slovenia

