



Cushyfoot Mounting



17/0290 | 17/0213 | 17/0346

Cushyfoot mountings

Cushyfoot mountings are suitable for many different types of machinery, e.g. diesel engines, generator sets, compressors, fans, hydraulic units and lift machinery.

Cushyfoot™ mountings have two rubber elements, used in shear and compression, to provide excellent stiffness characteristics for the isolation of a wide range of vibration frequencies.

There are three sizes, 17-0290 for loads up to 230 kg per mounting, 17-0213 for loads up to 1250 kg and 17-0346, which will carry up to 1280 kg per mounting, but will provide up to 16 mm static deflection.

The Cushyfoot mounting benefits from the following features:

- A wide load range from 50 to 1280 kg
- Clear branding for product identification
- Strong casting for safety and reliability
- Dissimilar horizontal stiffness gives optimum isolation and motion control

About Trelleborg Industrial AVS

Over 100 years of experience as Metalastik and Novibra, today Trelleborg Industrial AVS make improvements people can physically feel. From smoother travel to quieter, more efficient machines, we make life feel better. With quality, testing and compliance built in, we're in it for the long haul, ensuring your solution still works, over an extended and often arduous life-cycle.

With three state-of-the-art manufacturing plants across the globe, our experience in rubber to metal bonding enhances several industries, including off-highway vehicles, rail and mass transit, marine and energy and general industry.

We offer an end-to-end service, to take you from concept through design, manufacturing and testing to delivery. This reduces the complexity of supply, helping you cut costs, mitigate risk and receive on time, on budget delivery.

Trelleborg IAVS is part of Trelleborg Group, which employs 15,000 people in over 40 countries. Whatever your challenge, whatever your role and wherever you are, we are nearby to offer expert knowledge and quality solutions.

Cushyfoot 17/0290 | 17/0213 | 17/0346

Load per mounting (kg)

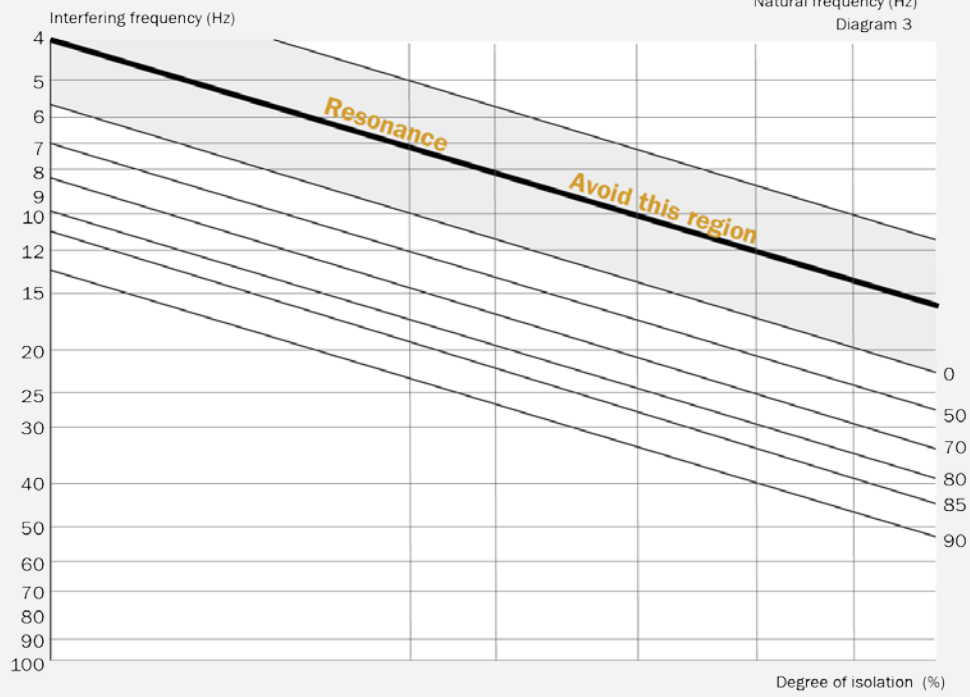
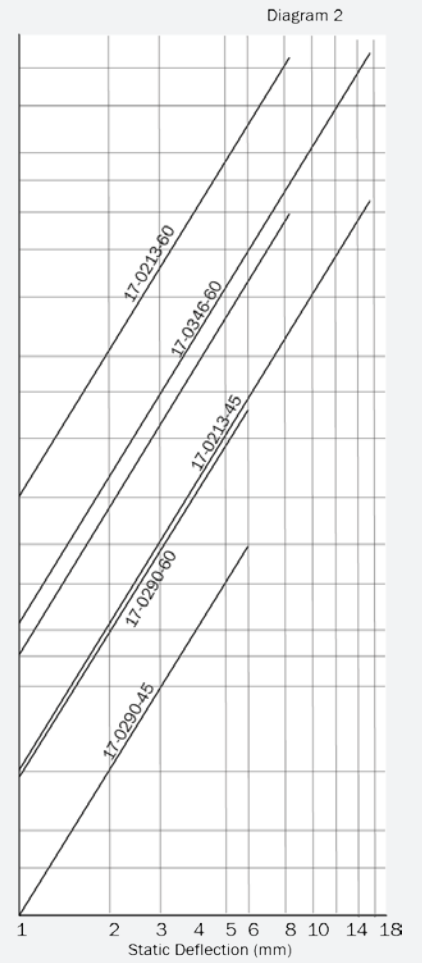
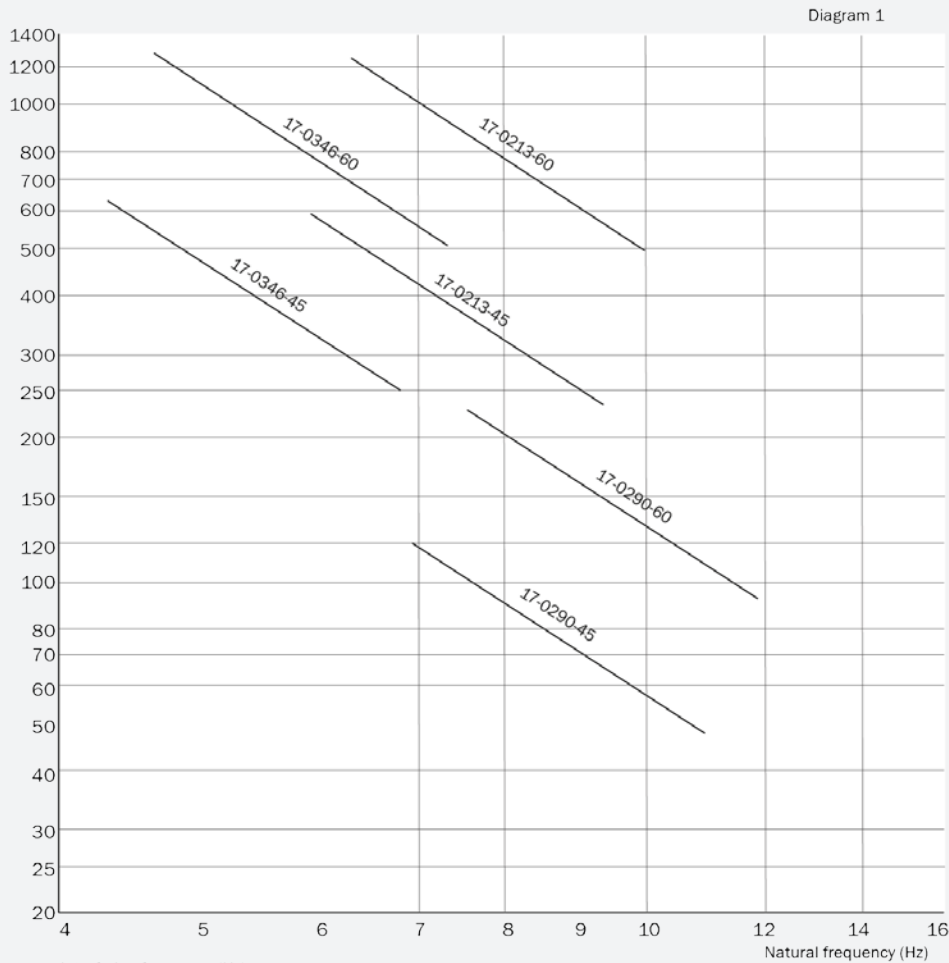

Note: The natural frequencies and degrees of isolation are based on dynamic characteristics on the mounting

Cushyfoot 17/0290 | 17/0213 | 17/0346

Technical Drawing

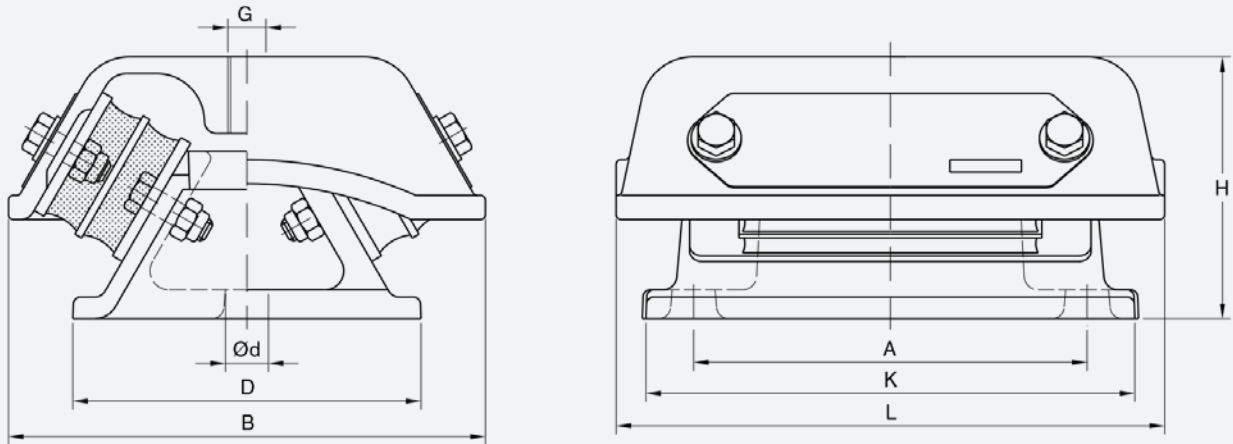

Product Data

DRAWING No.	PART No.	TYPE	DIMENSIONS (mm)								MAX LOAD (kg)	WEIGHT (kg)
			L	B	A	K	H	D	d	G		
17/0290	20-00689	45 IRH	122	132	90	114	72	82	13	M16	2.3	120
17/0290	10-04251	60 IRH										230
17/0213	10-04106	45 IRH	230	204	165	205	110	148	18	M16	10	590
17/0213	20-00688	60 IRH										1250
17/0346	10-04123	45 IRH	230	204	165	205	123	148	18	M16	9.5	630
17/0346	10-04120	60 IRH										1280



WWW.TRELLEBORG.COM/INDUSTIRALAVS

For further information visit our website or e-mail industrialavs@trelleborg.com

The content in this datasheet was correct at the time of printing, but is subject to change without notice.